



## ELECTRO-TECHNICS & ROTARY MACHINES

2023



## STUDY OF THE 3-PHASE ASYNCHRONOUS MOTOR 300W

### Ref. PACK-ACFR1

#### COMPOSITION OF THE SET

- 1 Squirrel cage three-phase induction motor
- 1 Powder brake
- 1 Torque sensor
- 1 DC tachogenerator
- 1 Variable three-phase power supply
- 1 Magnetoelectric voltmeter
- 1 AC & DC Multimeter Clamp
- 1 Display unit torque - speed - power
- 1 TRMS Wattmeter
- 1 Stand on wheels
- 1 Safety leads set



DELIVERED WITH TEACHING RESSOURCES

#### EDUCATIONAL OBJECTIVES

- Study the stator and the rotor of an asynchronous motor.
- Understand the STAR/DELTA motor coupling.
- Study the pairs number of poles and the influence on the rotating speed.
- Note, calculate and plot the electrical and mechanical quantities of the motor.

- Realize the balance sheet of motor powers.
- Understand the working of a powder brake.
- Use an ammeter clamp

### SQUIRREL CAGE INDUCTION MOTOR

This engine works as well with a speed variator as directly connected to a 3-phase supply.

U (V)	230/400V
I (A)	1.5 / 0.9
H / B / L	90 / 172 / 235mm
Weight	8.2 kg

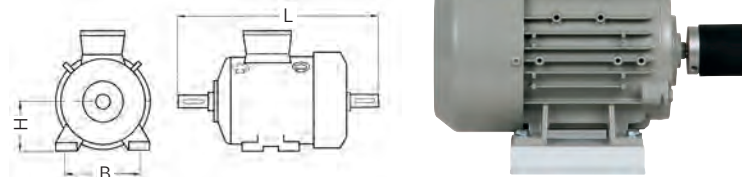

### POWDER BRAKE

Voltage/Current max for blocking	2V / 0,1A
Max torque	35Nm
H / B / L	90 x 172 x 240mm
Weight	18 kg
Ventilation	Natural

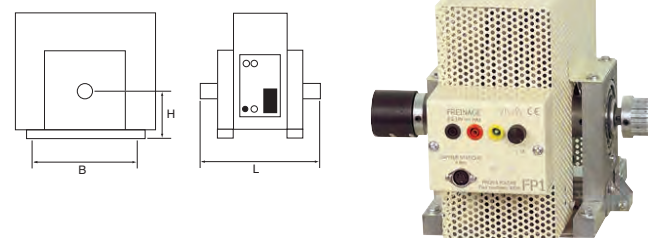

### TORQUE SENSOR

Sensor range	20 Nm
Use with	an important inertia
Torque output signal	0 to 5V for the measuring span in Nm (0 to -5V according the rotating way).
Maximum rotating speed	2000 rpm.
Sensor supply	between 12 and 28 VDC.

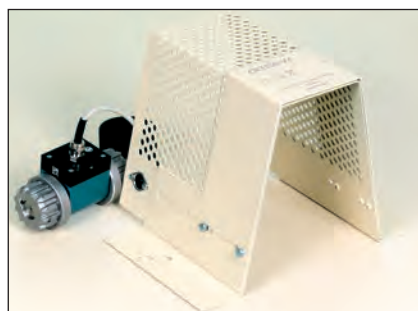

### DC TACHOGENERATOR

Deliver a continuous voltage proportional to the rotating speed.	
Voltage at 1000rpm	10V
Connector	safety terminals
H / B / L	90 x 172 x 170mm

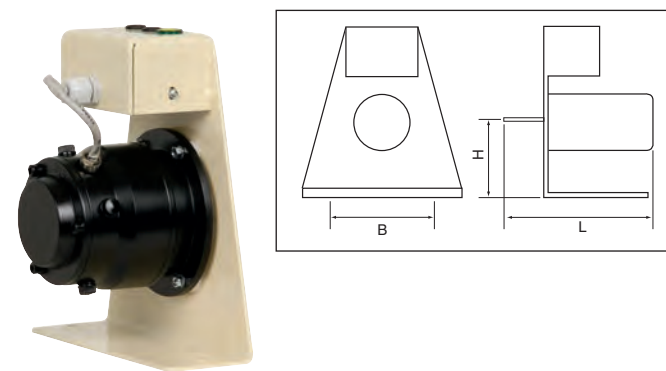

### AC VARIABLE POWER SUPPLY FOR 3-PHASE MACHINES

Cover design with circuit-breaker and light.  
Primary on mains cable.

Power	3.72kVA
Primary	380/400V
Secondary	0-430V
Secondary	5A
Weight	30kg
Dimensions	280 x 340 x 510mm



### SPEED - TORQUE - POWER DISPLAY UNIT

#### DIRECT DISPLAY

- of the mechanical torque in Nm
- of the speed of rotation in rpm
- of the power in W

Calculates internally the mechanical power  $P_u = M 2\pi n / 60$



### CLAMP / MULTIMETER AC & DC

- Auto power off after 25mm
- Recopy output 10mV/A 20kHz
- Back lighting of the screen

Display	4.000 counts
Converter	AC & DC
Bandwidth	50Hz to 500Hz
opening of the jaws	12mm
VDC / VAC	400mV to 600V
IDC / IAC	4 to 80A
OHM	4Ω to 40MΩ
Farad	40nF to 100μF
Fréquencymeter	5Hz to 10MHz
.....))	Ring for R < 150Ω
Ranging	Auto & Manual
Protection	CATIII 600Vrms pol2
Power source	2 batteries LR03
Dimensions / Weight	210 x 70 x 37mm / 200g



### SAFETY LEADS Ø4 REAR STACKING

- Very supple wire 30A
- Contacts formed into spring strips
- Working voltage 600V CAT III
- Test voltage 7400V during 1 mn
- Conforms to the standard CEI1010



### MAGNETOELECTRIC VOLTMETER

VDC	100mV to 1000V (1,5%)
VAC	3 to 1000V (2%)
Scale length	90mm
Protection	CAT III 600V Pol 2
Safety terminals	yes
Fuses	HPC 500V 500mA
Impedances	VDC : 20kΩ/V - VAC : 6,3kΩ/V
Dimensions / Weight	170 x 110 x 53mm / 500g



### TRMS WATTMETER



Function	U	I	W
Ranges	400Vrms single-phase 700Vrms 3-phase	20Arms	0.2 - 2 - 20kW
Accuracy in % of reading	1% from 0 to 50kHz	2% 0 ~ 20kHz 3% 20 ~ 50kHz	2% 0 ~ 20kHz 3% 20 ~ 30kHz 5% 30 ~ 70kHz
Protection	Electronic breaker	20A delayed fuse	
Impedance	1.5MΩ	<5mΩ	
Recopy outputs	10VDC/1000Vrms	10VDC/20Arms	10VDC/ 0,2kW - 2kW - 20kW

WATTELEC is a digital multimeter with floating inputs simultaneously displaying the 3 electric values: voltage, current and power. WATTELEC measures the TRMS effective values of the U I W measurements, possibly with direct component superimposed. The wide bandwidth of the apparatus allows measurements to be made from DC to 70kHz or on chopped signals (frequency converters, industrial choppers, rectified supplies etc.). The apparatus voltage and current inputs are insulated between each other and relative to earth. WATTELEC measures single phase and balanced three phase powers.  
DISPLAY  
Height of digits 14mm (text: 6mm).  
Power ranges are switched automatically.  
Supplied with user manual

### MOTORS STAND AND ACCESSORIES

The set is supplied with coupling, fastening, covers and guide rails



STUDY OF THE 3-PHASE ASYNCHRONOUS MOTOR & THE SYNCHRONOUS MACHINE 300W

Ref. PACK-ACAC1

COMPOSITION OF THE SET

- 1 Squirrel cage three-phase induction motor
- 1 3-phase synchronous machine - alternator
- 1 Torque sensor
- 1 DC tachogenerator
- 1 Variable three-phase power supply
- 1 Polar wheel power supply
- 1 Synchronoscope
- 1 Resistive load
- 1 Display unit torque and speed
- 3 Magnétoelectric voltmeters
- 2 Magnétoelectric ammeters
- 1 AC & DC multimeter clamp



DELIVERED WITH TEACHING RESSOURCES

EDUCATIONAL OBJECTIVES

- Study the stator and the rotor of an asynchronous motor.
- Study the pairs number of poles and the influence on the rotating speed.
- Note, calculate and plot the electrical and mechanical quantities of the motor.
- Realize the balance sheet of motor powers.
- Study the functioning of a synchronous machine in Hypo-synchrone and Hyper-synchrone connected to the national electrical grid.
- Understand the functioning and the use a synchronoscope.
- Study the functioning of a synchronous machine in Hypo-synchrone and Hyper-synchrone connected to a resistive load.
- Note, calculate and plot the electrical and mechanical quantities of the alternator.
- Use an ammeter clamp

SQUIRREL CAGE INDUCTION MOTOR

This engine works as well with a speed variator as directly connected to a 3-phase supply.

U (V)	230/400V
I (A)	1.5 / 0.9
H / B / L	90 / 172 / 235mm
Weight	8.2 kg

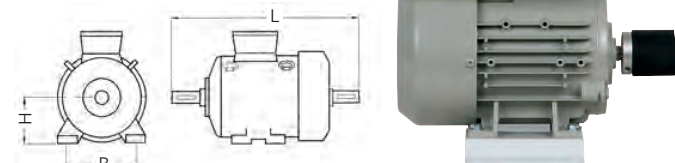

3-PHASE SYNCHRONOUS MACHINE

Works as a synchronous motor and 3-phase alternator. Equipped with LEBLANC poles for the mains network synchronization.

U (V)	230/400V
H / B / L	90 / 172 / 470mm
Weight	18 kg

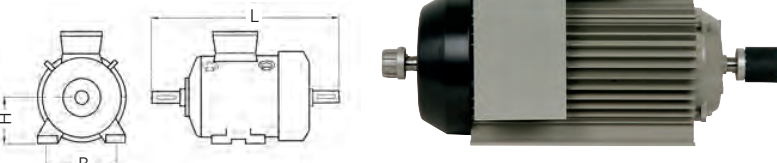

TORQUE SENSOR

Sensor range	20 Nm
Use with	an important inertia
Torque output signal	0 to 5V for the measuring span in Nm (0 to -5V according the rotating way).
Maximum rotating speed	2000rpm.
Sensor supply	between 12 and 28 VDC.

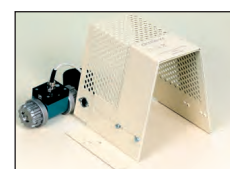

TORQUE & SPEED DISPLAY UNIT

Range (torque)	200,0 Nm
Analogical output	-5V / 0 / +5V
Range (speed)	2000 rpm



DC TACHOGENERATOR

Deliver a continuous voltage proportional to the rotating speed.  
 Voltage at 1000 rpm 10V  
 Connector safety terminals  
 H / B / L 90 x 172 x 170mm

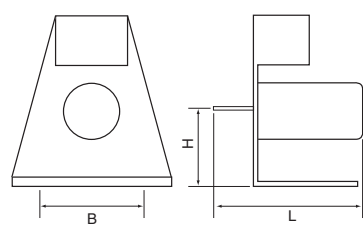

AC/AC FREQUENCY CONVERTER

PRIMARY IN 230V SINGLE-PHASE 50/60Hz  
 Output voltages: 3-phase 230V variable frequency.  
 For motor power 300W  
 Constant output current 4.4A  
 Maximum transient current 5A

RESISTIVE LOAD

Power 0.5kW  
 Nb switches: 6  
 Variation in steps of 5%  
 Type portable  
 Weight: 15kg



POLAR WHEEL POWER SUPPLY

INDEPENDENT 1	2 x 0 to 30V - 2 x 0 to 3A
SERIAL 1	0 to 60V - 0 to 3A
PARALLELE	0 to 30V - 0 to 6A
Dims	255 x 145 x 265mm
Weight	8kg
Power source	Mains 120-240V - 50/60Hz

SYNCHRONOSCOPE - 16A - 400V

Allows to securely connect a rotating electric machine to the national 3 x 400V power grid.  
 • 2 displays indicate the presence and order of the phases.  
 • 1 central display makes it possible to compare the voltage and frequency difference between the 3-phase 400V network and the rotating machine.  
 • 1 set of LEDs shows the best time to switch the synchronization switch on.



SAFETY LEADS Ø4 REAR STACKING

- Very supple wire 30A
- Contacts formed into spring strips
- Working voltage 600V CAT III
- Test voltage 7400V during 1 mn
- Conforms to the standard CEI1010

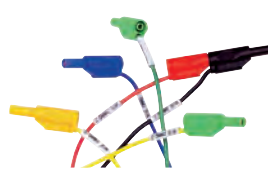

MAGNETOELECTRIC AMMETER

IDC	100µA to 10A (1,5%)
IAC	10mA to 10A (2%)
mV	100mV for the use of external shunts
Scale length	90mm
Protection	CAT III 600V Pol 2
Safety terminals	yes
Fuses	HPC 500V 3A + HPC 500V 10A
Dims / Weight	170 x 110 x 53mm / 500g



MAGNETOELECTRIC VOLTMETER

VDC	100mV to 1000V (1,5%)
VAC	3 to 1000V (2%)
Scale length	90mm
Protection	CAT III 600V Pol 2
Safety terminals	yes
Fuses	HPC 500V 500mA
Impedances	VDC : 20kΩ/V - VAC : 6,3kΩ/V
Dims / Weight	170 x 110 x 53mm / 500g



CLAMP / MULTIMETER AC & DC

- Auto power off after 25mn
  - Recopy output 10mV/A 20kHz
  - Back lighting of the screen
- |                     |                        |
|---------------------|------------------------|
| Display             | 4.000 counts           |
| Converter           | AC & DC                |
| Bandwidth           | 50Hz to 500Hz          |
| opening of the jaws | 12mm                   |
| VDC / VAC           | 400mV to 600V          |
| IDC / IAC           | 4 to 80A               |
| OHM                 | 4Ω to 40MΩ             |
| Farad               | 40nF to 100µF          |
| Fréquencymeter      | 5Hz to 10MHz           |
| ..)))               | Ring for R < 150Ω      |
| Ranging             | Auto & Manual          |
| Protection          | CATIII 600Vrms pol2    |
| Power source        | 2 batteries LR03       |
| Dimensions / Weight | 210 x 70 x 37mm / 200g |

MOTORS STAND AND ACCESSORIES

The pack is supplied with coupling, fastening, covers and guide rails

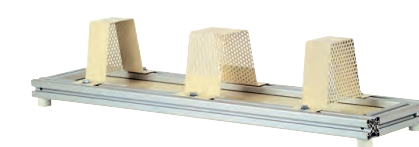

## STUDY OF THE DC MOTOR AND THE SYNCHRONOUS MACHINE 300W

### Ref. PACK-DCAC1

#### COMPOSITION OF THE SET

- 1 Shunt separated motor 220 / 220V
- 1 3-phase synchronous machine - alternator
- 1 Torque sensor
- 1 DC tachogenerator
- 1 Display unit torque and speed
- 1 Power supply inductor DC machine
- 1 Rheostat
- 1 Polar wheel power supply
- 1 Synchronoscope
- 1 Resistive load
- 4 Magnétoelectric voltmeters
- 3 Magnétoelectric ammeters
- 1 AC & DC multimeter clamp

#### EDUCATIONAL OBJECTIVES

- Study the armature/inductor windings of a DC machine.
- Understand the influence of the Inductor winding on the speed of rotation.
- Note the voltages and currents in the armature and in the inductor.
- Note, calculate and plot the electrical and mechanical quantities of the motor.
- Realize the balance sheet of motor powers.
- Study the functioning of a synchronous machine in Hypo-synchrone and Hyper-synchrone connected to the national electrical grid.
- Understand the functioning and the use a synchronoscope.
- Study the functioning of a synchronous machine in Hypo-synchrone and Hyper-synchrone connected to a resistive load.
- Note, calculate and plot the electrical and mechanical quantities of the alternator.
- Use an ammeter clamp



DELIVERED WITH TEACHING RESSOURCES

### SHUNT SEPARATED MOTOR 220/220V

This engine works as well with a speed variator as directly connected to a DC supply.

U (V)	220/230V
I (A)	2A under 230V
H / B / L	90 / 172 / 390mm
Weight	21 kg

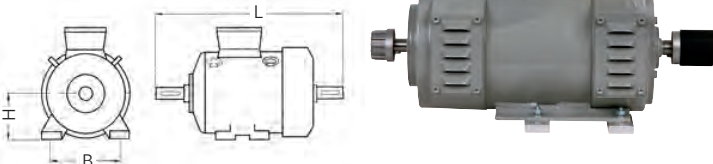

### 3-PHASE SYNCHRONOUS MACHINE

Works as a synchronous motor and 3-phase alternator. Equipped with LEBLANC poles for the mains network synchronization.

U (V)	230/400V
H / B / L	90 / 172 / 470mm
Weight	18 kg

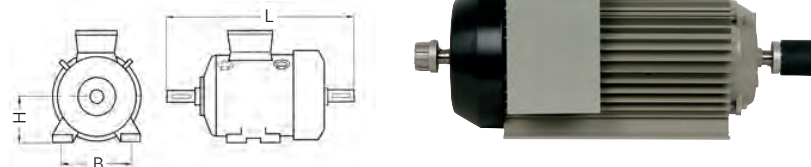

### TORQUE SENSOR

Sensor range	20 Nm
Use with	an important inertia
Torque output signal	0 to 5V for the measuring span in Nm (0 to -5V according the rotating way).
Maximum rotating speed	2000rpm.
Sensor supply	between 12 and 28 VDC.

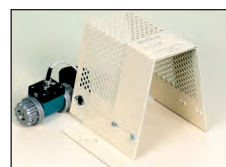

### TORQUE & SPEED DISPLAY UNIT

Range (torque)	200,0 Nm
Analogical output	-5V / 0 / +5V
Range (speed)	2000 rpm



### DC TACHOGENERATOR

Deliver a continuous voltage proportional to the rotating speed.  
Voltage at 1000 rpm 10V  
Connector safety terminals  
H / B / L 90 x 172 x 170mm

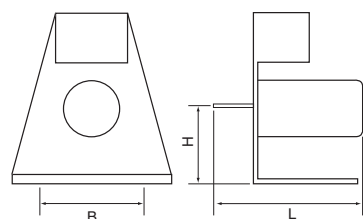

### POLAR WHEEL POWER SUPPLY

INDEPENDENT 1	2 x 0 to 30V - 2 x 0 to 3A
SERIAL 1	0 to 60V - 0 to 3A
PARALLEL	0 to 30V - 0 to 6A
Dims/ Weight	255 x 145 x 265mm / 8kg
Power source	Mains 120-240V - 50/60Hz



### RHEOSTAT FOR INDUCTOR

0 to 100Ω / 1.8A



### POWER SUPPLY INDUCTOR DC MACHINES

This power supply includes :

- one variable DC supply with voltmeter & ammeter
- one fixed DC supply

Protection of users is ensured by galvanic insulation of outputs.

- Mains: Mains cable
- On/Off: General switch and light
- DC variable output: 0-240V / 3A
- DC fixed output: 2300V / 1A
- Input protection: by time delay fuses
- Output protection: by thermal magnetic circuit-breakers
- Smoothing: by capacitors
- Dimensions / weight: 210 x 245 x 350mm / 20 kg.



### RESISTIVE LOAD

Power 0.5kW  
Nb switches: 6  
Variation in steps of 5%  
Portable type  
Weight: 15 kg



### MAGNETOELECTRIC AMMETER

IDC	100μA to 10A (1,5%)
IAC	10mA to 10A (2%)
mV	100mV for the use of external shunts
Scale length	90mm
Protection	CAT III 600V Pol 2
Safety terminals	yes
Fuses	HPC 500V 3A + HPC 500V 10A
Dims / Weight	170 x 110 x 53mm / 500g



### MAGNETOELECTRIC VOLTMETER

VDC	100mV to 1000V (1,5%)
VAC	3 to 1000V (2%)
Scale length	90mm
Protection	CAT III 600V Pol 2
Safety terminals	yes
Fuses	HPC 500V 500mA
Impedances	VDC : 20kΩ/V - VAC : 6,3kΩ/V
Dims / Weight	170 x 110 x 53mm / 500g



### CLAMP / MULTIMETER AC & DC

- Auto power off after 25mn
- Recopy output 10mV/A 20kHz
- Back lighting of the screen
- Display 4.000 counts
- Converter AC & DC
- Bandwidth 50Hz to 500Hz
- opening of the jaws 12mm
- VDC / VAC 400mV to 600V
- IDC / IAC 4 to 80A
- OHM 4Ω to 40MΩ
- Farad 40nF to 100μF
- Fréquencymeter 5Hz to 10MHz
- ..))) Ring for R < 150Ω
- Ranging Auto & Manual
- Protection CATIII 600Vrms pol2
- Power source 2 batteries LR03
- Dimensions / Weight 210 x 70 x 37mm / 200g



### SYNCHRONOSCOPE - 16A - 400V

Allows to securely connect a rotating electric machine to the national 3 x 400V power grid.

- 2 displays indicate the presence and order of the phases.
- 1 central display makes it possible to compare the voltage and frequency difference between the 3-phase 400V network and the rotating machine.
- 1 set of LEDs shows the best time to switch on the synchronization.

### SAFETY LEADS Ø4 REAR STACKING

- Very supple wire 30A
- Contacts formed into spring strips
- Working voltage 600V CAT III
- Test voltage 7400V during 1 mn
- Conforms to the standard CEI1010

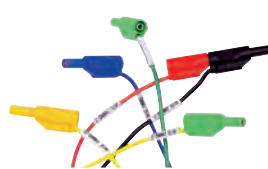

### MOTORS STAND AND ACCESSORIES

The set is supplied with coupling, fastening, covers and guide rails.



## STUDY OF THE DC POLYEXCITATION MOTOR 300W

### Ref. PACK-DCFR1

#### COMPOSITION OF THE SET

- 1 Polyexcitation motor
- 1 Powder brake
- 1 Torque sensor
- 1 DC tachogenerator
- 1 Power supply for brake
- 1 Display unit torque and speed
- 1 Power supply inductor DC machine
- 1 Rheostat
- 2 Magnétoelectric voltmeters
- 1 Magnétoelectric ammeter
- 1 AC & DC multimeter clamp



DELIVERED WITH TEACHING RESSOURCES

#### EDUCATIONAL OBJECTIVES

- Study the armature/inductor windings of a DC machine.
- Understand the influence of the Inductor winding on the speed of rotation.
- Measure the voltages and currents in the armature and inductor.
- Note, calculate and plot the electrical and mechanical quantities of the motor.
- Realize the balance sheet of motor powers.
- Understand the working of a powder brake.
- Use an ammeter clamp

### POLYEXCITATION MOTOR

Driven motor (can operate in hypersynchronous generator).

U (V)	220V
I (A)	2.2A
H / B / L	90 / 172 / 420mm
Weight	26 kg

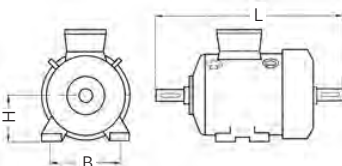

### POWDER BRAKE

Voltage/Current max for blocking	2V / 0,1A
Max torque	35Nm
H / B / L	90 x 172 x 240mm
Weight	18 kg
Ventilation	Natural

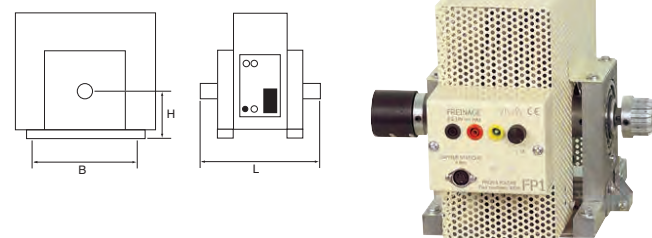

### TORQUE SENSOR

Sensor range	20 Nm
Use with	an important inertia
Torque output signal	0 to 5V for the measuring span in Nm (0 to -5V according the rotating way).
Maximum rotating speed	2000 rpm.
Sensor supply	between 12 and 28 VDC.

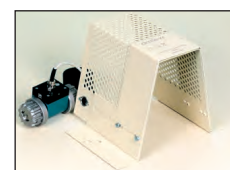

### TORQUE & SPEED DISPLAY UNIT

Range (torque)	200,0 Nm
Analogical output	-5V / 0 / +5V
Range (speed)	2000 rpm



### DC TACHOGENERATOR

Deliver a continuous voltage proportional to the rotating speed.	
Voltage at 1000rpm	10V
Connector	safety terminals
H / B / L	90 x 172 x 170mm

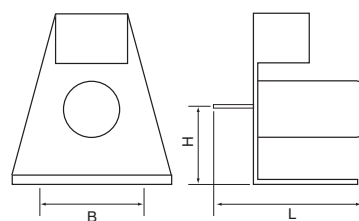

### POWER SUPPLY INDUCTOR DC MACHINES

This power supply includes :

- one variable DC supply with voltmeter & ammeter
- one fixed DC supply

Protection of users is ensured by galvanic insulation of outputs.

- Mains: Mains cable
- On/Off: General switch and light
- DC variable output: 0-240V / 3A
- DC fixed output: 230V / 1A
- Input protection: by time delay fuses
- Output protection: by thermal magnetic circuit-breakers
- Smoothing: by capacitors
- Dimensions / weight: 210 x 245 x 350mm / 20 kg



### RHEOSTAT FOR INDUCTOR

0 to 1500Ω / 0.65A



### MAGNETOELECTRIC AMMETER

IDC	100μA to 10A (1,5%)
IAC	10mA to 10A (2%)
mV	100mV for the use of external shunts
Scale length	90mm
Protection	CAT III 600V Pol 2
Safety terminals	yes
Fuses	HPC 500V 3A + HPC 500V 10A
Dims / Weight	170 x 110 x 53mm / 500g

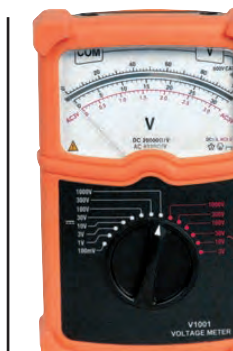

### MAGNETOELECTRIC VOLTMETER

VDC	100mV to 1000V (1,5%)
VAC	3 to 1000V (2%)
Scale length	90mm
Protection	CAT III 600V Pol 2
Safety terminals	yes
Fuses	HPC 500V 500mA
Impedances	VDC : 20kΩ/V - VAC : 6,3kΩ/V
Dims / Weight	170 x 110 x 53mm / 500g



### MAGNETOELECTRIC VOLTMETER

- Auto power off after 25mn
- Recopy output 10mV/A 20kHz
- Back lighting of the screen

Display	4.000 counts
Converter	AC & DC
Bandwidth	50Hz to 500Hz
opening of the jaws	12mm
VDC / VAC	400mV to 600V
IDC / IAC	4 to 80A
OHM	4Ω to 40MΩ
Farad	40nF to 100μF
Fréquencymeter	5Hz to 10MHz
..)))	Ring for R < 150Ω
Ranging	Auto & Manual
Protection	CATIII 600Vrms pol2
Power source	2 batteries LR03
Dimensions / Weight	210 x 70 x 37mm / 200g

### POWER SUPPLY FOR BRAKE

Current control is devised around a microcontroller circuit providing high precision of the delivered current.

Manual control of the brake.

- Mains power supply 230V AC - 50/60 Hz
- Max output current 2A.
- Output load 4-20 ohms
- Brake control analogue input signal 0-10V DC
- Dimensions: 240 x 180 x 130 mm



### SAFETY LEADS Ø4 REAR STACKING

- Very supple wire 30A
- Contacts formed into spring strips
- Working voltage 600V CAT III
- Test voltage 7400V during 1 mn
- Conforms to the standard CEI1010



### MOTORS STAND AND ACCESSORIES

The set is supplied with coupling, fastening, covers and guide rails



## STUDY OF THE 3-PHASE ASYNCHRONOUS MOTOR & THE DC GENERATOR 300W

### Ref. PACK-ACDC1

#### COMPOSITION OF THE SET

- 1 Squirrel cage three-phase motor
- 1 Shunt separated DC generator
- 1 Torque sensor
- 1 DC tachogenerator
- 1 Variable three-phase power supply
- 1 Resistive load
- 1 Power supply inductor DC machine
- 1 Rheostat
- 1 Display unit torque and speed
- 3 Magnetolectric voltmeters
- 2 Magnetolectric ammeters
- 1 AC & DC multimeter clamp



DELIVERED WITH TEACHING RESSOURCES

#### EDUCATIONAL OBJECTIVES

- Study the stator and the rotor of an asynchronous motor.
- Study the pairs number of poles and the influence on the rotating speed.
- Note, calculate and plot the electrical and mechanical quantities of the motor.
- Realize the balance sheet of motor powers.
- Study the armature/inductor windings of a DC machine.
- Understand the influence of the Inductor winding on the speed of rotation.
- Note the voltages and currents in the armature and in the inductor.
- Note, calculate and plot the electrical and mechanical quantities of the generator.
- Realize the balance sheet of generator powers.
- Use an ammeter clamp.

### SQUIRREL CAGE INDUCTION MOTOR

This engine works as well with a speed variator as directly connected to a 3-phase supply.

U (V)	230/400V
I (A)	1.5 / 0.9
H / B / L	90 / 172 / 235mm
Weight	8.2 kg

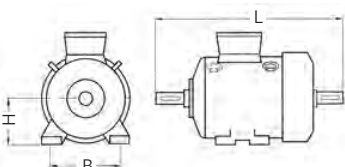
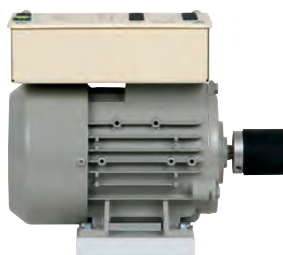

### SHUNT SEPARATE DC GENERATOR

U (V)	220V
I (A)	2A
H / B / L	90 / 172 / 420mm
Weight	20 kg

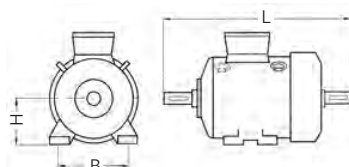

### TORQUE SENSOR

Sensor range	20 Nm
Use with	an important inertia
Torque output signal	0 to 5V for the measuring span in Nm (0 to -5V according the rotating way).
Maximum rotating speed	2000 rpm.
Sensor supply	between 12 and 28 VDC.



### TORQUE & SPEED DISPLAY UNIT

Range (torque)	200,0 Nm
Analogical output	-5V / 0 / +5V
Range (speed)	2000 rpm



### DC TACHOGENERATOR

Deliver a continuous voltage proportional to the rotating speed.  
Voltage at 1000 rpm 10V  
Connector safety terminals  
H / B / L 90 x 172 x 170mm

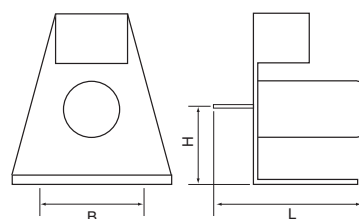

### POWER SUPPLY INDUCTOR DC MACHINES

This power supply includes :

- one variable DC supply with voltmeter & ammeter
- one fixed DC supply

Protection of users is ensured by galvanic insulation of outputs.

- Mains: Mains cable
- On/Off: General switch and light
- DC variable output: 0-240V / 3A
- DC fixed output: 230V / 1A
- Input protection: by time delay fuses
- Output protection: by thermal magnetic circuit-breakers
- Smoothing: by capacitors
- Dimensions / weight: 210 x 245 x 350mm / 20 kg



### RESISTIVE LOAD

Power 0.5kW  
Nb switches: 6  
Variation in steps of 5%  
Portable type  
Weight: 15 kg



### MAGNETOELECTRIC AMMETER

IDC	100µA to 10A (1,5%)
IAC	10mA to 10A (2%)
mV	100mV for the use of external shunts
Scale length	90mm
Protection	CAT III 600V Pol 2
Safety terminals	yes
Fuses	HPC 500V 3A + HPC 500V 10A
Dims / Weight	170 x 110 x 53mm / 500g



### MAGNETOELECTRIC VOLTMETER

VDC	100mV to 1000V (1,5%)
VAC	3 to 1000V (2%)
Scale length	90mm
Protection	CAT III 600V Pol 2
Safety terminals	yes
Fuses	HPC 500V 500mA
Impedances	VDC : 20kΩ/V - VAC : 6,3kΩ/V
Dims / Weight	170 x 110 x 53mm / 500g

### AC/AC FREQUENCY CONVERTER

PRIMARY IN 230V SINGLE-PHASE 50/60Hz  
Output voltages: 3-phase 230V variable frequency  
Constant output current 4.4A  
Maximum transient current 5A



### RHEOSTAT FOR INDUCTOR

0 to 3300Ω / 0.44A



### SAFETY LEADS Ø4 REAR STACKING

- Very supple wire 30A
- Contacts formed into spring strips
- Working voltage 600V CAT III
- Test voltage 7400V during 1 mn
- Conforms to the standard CEI1010

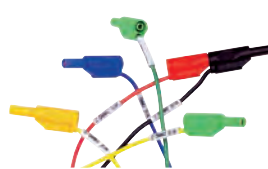

### MOTORS STAND AND ACCESSORIES

The set is supplied with coupling, fastening, covers and guide rails.



# STUDYING THE 1.5KW ASYNCHRONOUS MOTOR & 3-PHASE ALTERNATOR

## DESCRIPTION OF THE 18 ITEMS INCLUDED IN PACK-AC2 REFERENCE

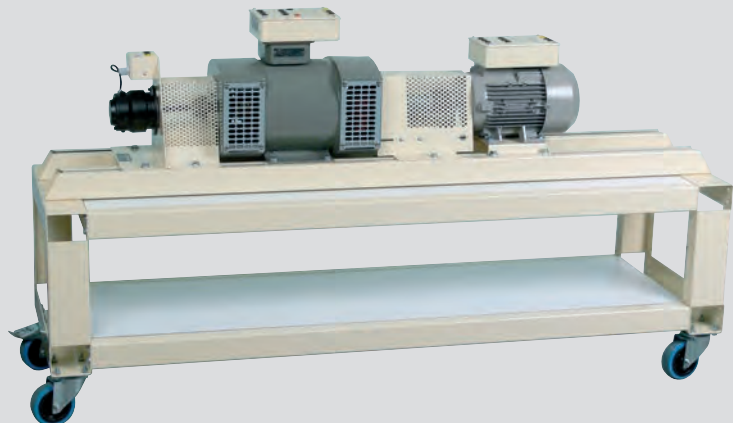

3-phase asynchronous motor Ref. MAS22 - Qty 1	3-phase alternator Ref. MSM20 - Qty 1	Stand on wheels Ref. CTC - Qty 1
Rotary torque sensor Ref. CR2-V2 - Qty 1	DC tachogenerator Ref. DYTA2 - Qty 1	Guide rails Ref. RGC - Qty 1
 DC variable supply Ref. COMPAK40 - Qty 1	 2000W Resistive load Ref. RHP20 - Qty 1	 3-phase wattmeter Ref. W17 - Qty 1
 Synchronoscope Ref. CHR3 - Qty 1	 Safety wattmeter switch Ref. COWATT11 - Qty 1	 Magnetolectric voltmeter Ref. V1001 - Qty 1
 Digital wattmeter Ref. WATTELEC - Qty 1	 Measurement of mechanical quantities Ref. MECAWATT2 - Qty 1	 Rheostat Ref. ECO2-106 - Qty 1
 Set of 67 safety leads Ref. 400S - Qty 1 set	 20A magnetolectric ammeter Ref. A11 - Qty 1	 Frequency converter Ref. ACVAR5 - Qty 1

### OPERATING PRINCIPLE

A 1500W asynchronous motor, powered by a 3 X 400V source, is charged by means of an alternator. The electrical power generated by the alternator is drained either in the form of an adjustable resistive charge or throughout the public network. The power consumed by the motor is measured using the "two powers" method by using a wattmeter switch and an analogue wattmeter. The voltage and current consumed by the motor are measured using an analogue voltmeter and ammeter. On the alternator, the electrical quantities such as power, voltage and current supply are measured using a digital wattmeter with three displays. A brushless torque sensor (requiring no maintenance) measures the motor torque, whereas the tachometer generator measures the rotation speed. An analogue unit with three displays shows the torque, speed and useful power values.

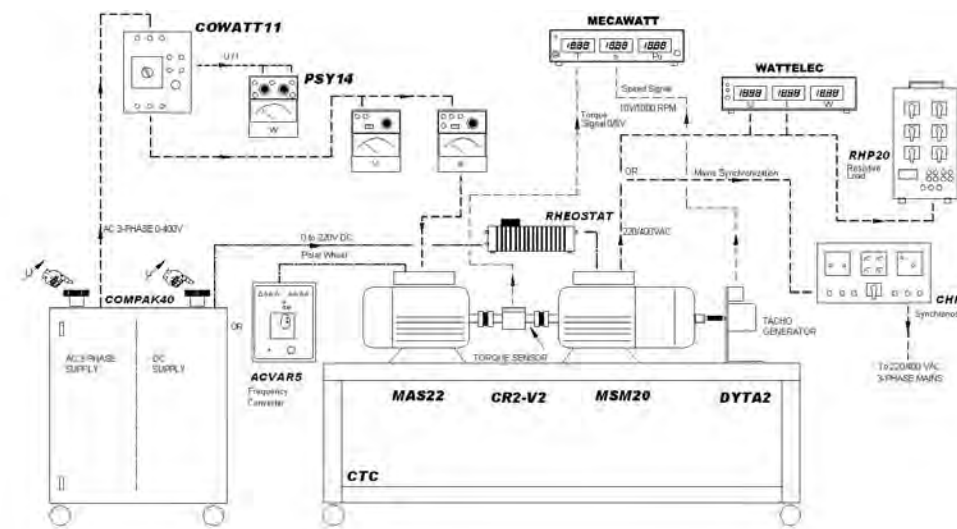
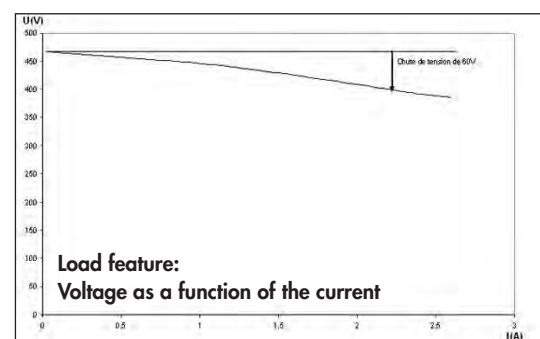
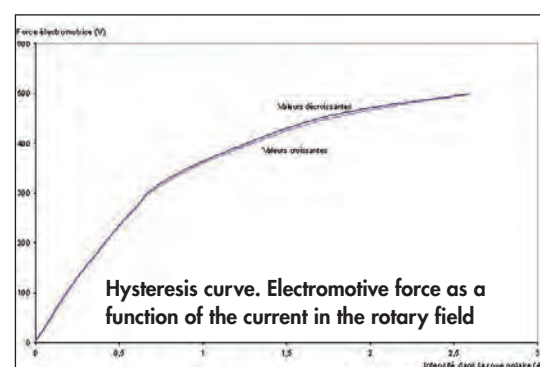
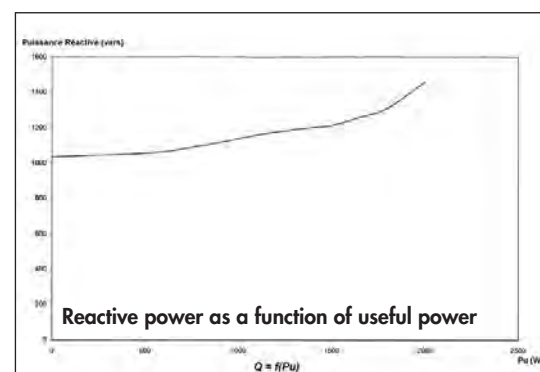

The PACK-AC2 power unit kit (power unit + accessories) can be used for studying a 1500W asynchronous motor.

Charged by a 1500W three-phase alternator, the charge properties are plotted based on measurements taken by various analogue or digital devices.

Comprises 18 items, motors + accessories.

ref. PACK-AC2  
ALSO AVAILABLE IN 300W. CONTACT US.

## TUTORIALS DESCRIBED IN THE INSTRUCTIONS SUPPLIED WITH PACK-AC2

### STUDY OF THE ASYNCHRONOUS INDUCTION MOTOR

- Study of the star/delta coupling of the asynchronous motor.
  - Understanding and undertaking motor wiring.
  - Measurements and comparison of the various voltage and current values according to the coupling type selected.
- Study of the "two powers" method.
  - Understanding and undertaking of wiring.
  - Power measurements P1/P2.
  - Calculation of the total power and total speed consumed by the motor.
- Study of motor operation with no load, with a load and with an overload, using the 1500W alternator.
  - Theoretical reminders of the mathematical formulae concerning an asynchronous motor.
  - Understanding and undertaking motor wiring with measuring devices.
  - Calculations of the electrical and mechanical quantities of the motor using its identification plate, such as:
    - ✓ Synchronism speed
    - ✓ Slip
    - ✓ Power consumption
    - ✓ Reactive power
    - ✓ Current consumption
    - ✓ Rotation speed
    - ✓ Motor torque
    - ✓ Apparent power
    - ✓ Slip
  - Creation of a table containing calculations and measurements of electrical and mechanical quantities at various points of the motor load:
    - ✓ Number of pairs of motor poles
    - ✓ Torque
    - ✓ Efficiency
    - ✓ Apparent power
    - ✓ Power consumption
    - ✓ Useful power
    - ✓ Power factor
    - ✓ Reactive power
    - ✓ Efficiency
  - Comparison of the theoretical calculation of values with those values measured during the motor tests
  - Plotting of properties based on motor measurements such as:
    - ✓ Torque as a function of useful power\*
    - ✓ Efficiency as a function of useful power\*
    - ✓ Current as a function of useful power\*
    - ✓ Rotation speed as a function of useful power\*
    - ✓ Slip as a function of useful power\*

### STUDY OF THE ALTERNATOR

- Study of the star/delta coupling of the asynchronous motor.
  - Understanding and undertaking alternator wiring.
  - Measurements and comparison of the various voltage and current values according to the coupling type selected.
- Study of alternator operation with no load, with a load and with an overload, using a resistive load:
  - Theoretical reminders of the mathematical formulae which apply to the alternator.
  - Understanding and undertaking alternator wiring with measuring devices.
  - Measurement and plotting of the properties of the magnetic circuit's hysteresis cycle.
  - Calculations of the electrical quantities of the alternator based on its identification plate, such as:
    - ✓ Number of pairs of poles
    - ✓ Power supplied
    - ✓ Power consumed by the rotary field
    - ✓ Joule loss
  - Creation of a table containing calculations and measurements of electrical and mechanical quantities at various points of the motor load
  - Comparison of the theoretical calculation of values with those values measured during the practical tests
  - Plotting the properties of the alternator's load:
    - ✓ voltage as a function of the supplied current
  - Calculation of the voltage decrease as a function of the load
  - Theoretical plotting of the shapes of the capacitive and inductive loads, compared with a resistive load
  - Analysis of results and conclusion
- Study of the operation of the synchronised alternator on the public network
  - Understanding and undertaking alternator wiring on the network.
  - Use of the speed controller
  - Use of the synchronoscope with its various displays
  - Synchronisation on the mains network
- Study of the operation of a short-circuited alternator:
  - Measurement of the short-circuit current & the current in the rotary field
  - Plotting of properties

DELIVERED COMPLETE WITH TEACHING RESOURCES  
STUDENT BOOKLET : THEORETICAL STUDIES & PRACTICAL WORKS  
TEACHER BOOKLET : WITH CORRECT VERSIONS OF THE PRACTICAL WORKS

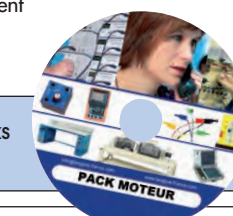

# STUDYING THE 1.5KW ASYNCHRONOUS MOTOR WITH PC MONITORING

The PACK-AC1 power unit kit (power unit + accessories) can be used for studying the short-circuited 220/400V 1500W, 3-phase, asynchronous induction motor with rotor in short-circuit.

Several measurements can be taken and the motor load properties can be monitored on a PC.

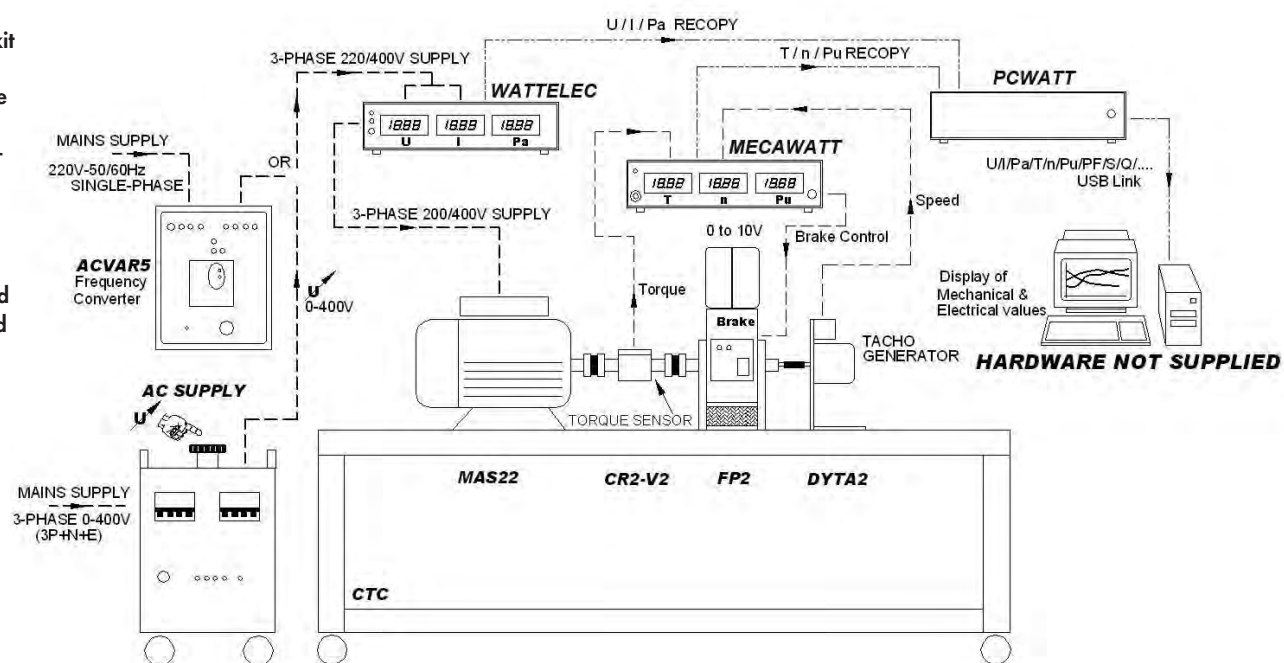

ref. PACK-AC1  
ALSO AVAILABLE IN 300W. CONTACT US.

## TUTORIALS DESCRIBED IN THE INSTRUCTIONS SUPPLIED WITH PACK-AC1

- **Study of the star/delta coupling of the asynchronous motor.**
  - Understanding and undertaking motor wiring.
  - Measurements and comparison of the various voltage and current values according to the coupling type selected.
  - Measurement of properties on a PC.
- **Study of the operation of the motor controlled by the speed controller (frequency converter)**
  - Understanding and undertaking the wiring of the speed controller to the motor.
  - Adjustment of speed controller settings.
  - Adjustment of motor acceleration and deceleration rotation speed settings.
  - Measurement on a PC of the rotation speed properties as a function of time.
- **Study of motor operation with no load, with a load and with an overload, using the 230/400V three-phase power supply.**
  - Theoretical reminders of the mathematical formulae concerning an asynchronous induction motor.
  - Understanding and undertaking motor wiring with measuring and monitoring devices.
  - Calculation of the electrical and mechanical quantities of the motor based on its identification plate, such as:
    - ✓ Synchronism speed
    - ✓ Number of pairs of motor poles
    - ✓ Slip
    - ✓ torque
    - ✓ Efficiency
  - ✓ Apparent power
  - Creation of a table containing calculations and measurements of electrical and mechanical quantities at various points of the motor load:
    - ✓ Current consumption
    - ✓ Power consumption
    - ✓ Rotation speed
    - ✓ Useful power
    - ✓ Motor torque
    - ✓ Power factor
    - ✓ Apparent power
    - ✓ Reactive power
    - ✓ Slip
    - ✓ Efficiency
  - Monitoring on the PC and comments about the various motor load curves
  - Comparison of the theoretical calculation of values with those values measure during the motor tests
  - Plotting of properties based on motor measurements such as:
    - ✓ Torque as a function of the speed (or other variable)
    - ✓ Torque as a function of useful power (or other variable)
    - ✓ Efficiency as a function of useful power (or other variable)
    - ✓ Reactive power as a function of useful power (or other variable)
    - ✓ Current as a function of useful power (or other variable)
    - ✓ Power factor as a function of useful power (or other variable)
    - ✓ Rotation speed as a function of useful power (or other variable)
    - ✓ Slip as a function of useful power (or other variable)

DELIVERED COMPLETE WITH TEACHING RESOURCES  
STUDENT BOOKLET : THEORETICAL STUDIES & PRACTICAL WORKS  
TEACHER BOOKLET : WITH CORRECT VERSIONS OF THE PRACTICAL WORKS



### OPERATING PRINCIPLE

A speed controller, constant V/F frequency converter, controls the motor's rotation speed according to the various acceleration or deceleration ramps. A three-phase power supply on casters is also used to supply power to the motor, replacing the speed controller.

A 1500W ventilated powder brake loads the motor with values of between 0 and 125% inclusive of the rated load. A brushless torque sensor (requiring no maintenance) measures the various torque values, whereas a DC tachogenerator provides an image signal of the motor's rotation speed.

A first unit, with three digital displays, shows the electrical quantities such as voltage, current and power used by the motor. The second unit, which also has three displays, shows the mechanical quantities such as torque, rotation speed and useful power.

All of these quantities, as well as the motor load curves, can be displayed in real time on a PC, before being printed out.

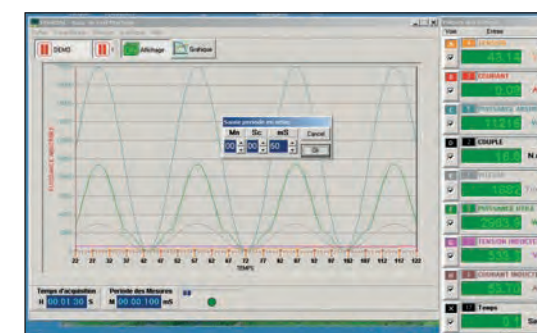

Example of monitoring with a display of curves and values

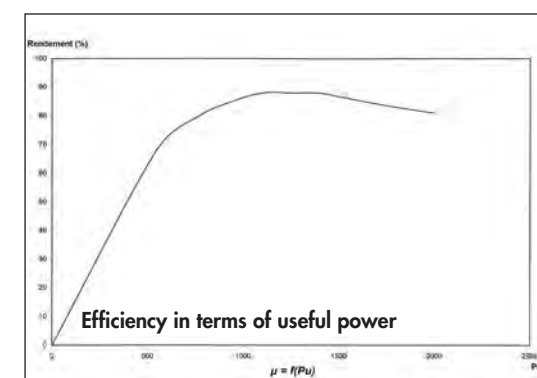
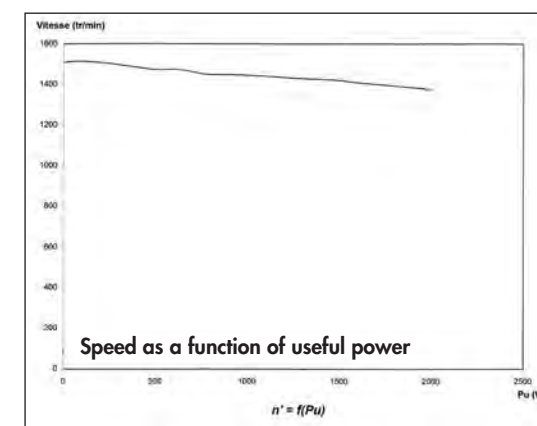

### DESCRIPTION OF THE 12 ITEMS INCLUDED IN PACK-AC1 REFERENCE

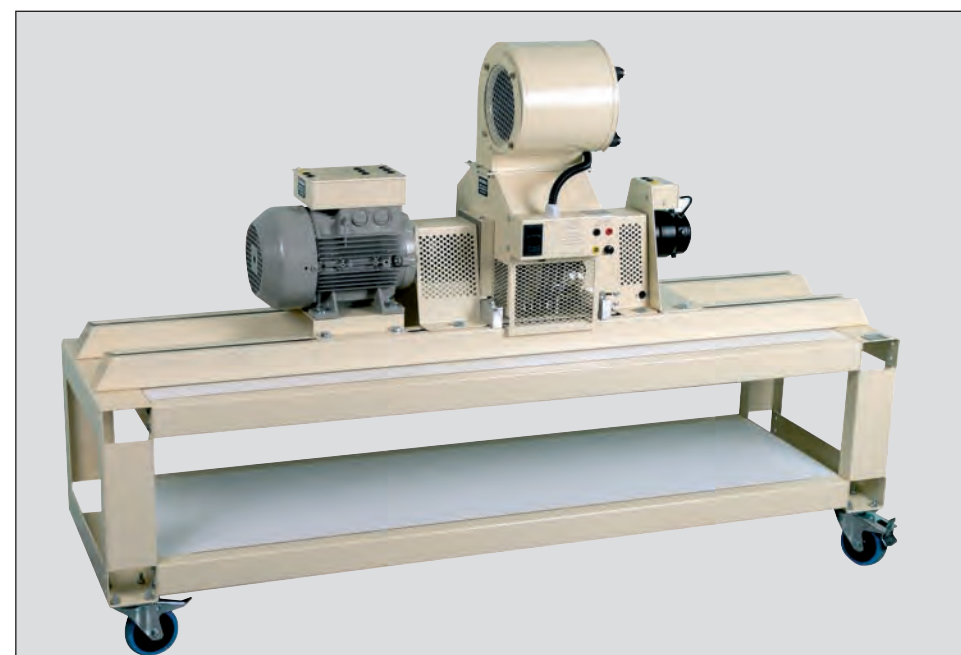

3-phase asynchronous motor Ref. MAS22 - Qty 1	Powder brake Ref. FP2 - Qty 1	Stand on wheels Ref. CTC - Qty 1
Rotary torque sensor Ref. CR2-V2 - Qty 1	DC tachogenerator Ref. DYTA2 - Qty 1	Guide rails Ref. RGC - Qty 1
3-phase supply on wheels Ref. TRT8PE - Qty 1	Frequency converter Ref. ACVAR5 - Qty 1	Set of 38 safety leads Ref. 4005 - Qty 1 set
Digital wattmeter Ref. WATTELEC - Qty 1	Measurement of mechanical quantities Ref. MECAWATT2 - Qty 1	Real time and monitoring system Ref. PCWATT - Qty 1



## STUDYING THE 1.5KW DC MOTOR

### DESCRIPTION OF THE 19 ITEMS INCLUDED PACK-DC1 REFERENCE

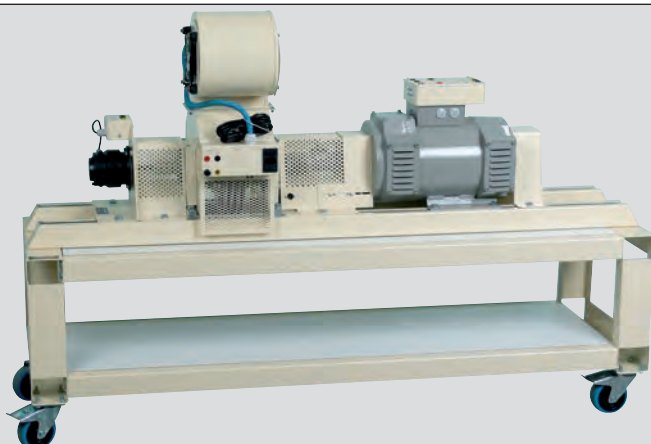

DC motor Ref. CC20 - Qty 1	Powder brake Ref. FP2 - Qty 1	Stand on wheels Ref. CTC - Qty 1 Guide rails Ref. RGC - Qty 1
Rotary torque sensor Ref. CR2-V2 - Qté 1	DC tachogenerator Ref. DYTA2 - Qté 1	
 DC variable supply Ref. COMPAK40 - Qty 1	 Wattmeter Ref. W17 - Qty 1	 Magnetolectric voltmeter Ref. V1001 - Qty 2
 20A magnetolectric Ammeter Ref. A11 - Qty 2	 Power supply master/slave Ref. GPS3303 - Qty 1	 Torque measuring interface for brushless sensor Ref. INTER-SB - Qty 1
 Multimeter Ref. TRG803 - Qty 2	 Safety starter Rheostat Ref. REDA34 - Qty 1	 Rheostat Ref. ECO1-470 - Qty 1
 Set of 46 safety leads Ref. 400S - Qty 1 set		

ref. PACK-DC1  
ALSO AVAILABLE IN 300W. CONSULT US.

### TUTORIAL WITH PACK-DC1

- **Study of connection schematics with shunt excitation and separate excitation (independent).**
  - Understanding and undertaking motor wiring depending on the selected excitation type.
  - Measurements and comparisons of the various consumed power, voltage and current values depending on the selected excitation type.
- **Calculation method used for determining the resistance value:**
  - of the start-up rheostat
  - of the excitation rheostat
- **Study of the motor's operation when unloaded, when loaded and when overloaded with separate excitation (independent) and with shunt excitation:**
  - Theoretical reminders of the mathematical formulae applying to a DC motor.
  - Understanding and undertaking motor wiring with measuring devices.
  - Creation of a table containing calculations and measurements of electrical and mechanical quantities at various points of the motor load:
    - ✓ Current consumption of field system/in the rotor
    - ✓ Power consumption of field system/in the rotor
    - ✓ Rotation speed
    - ✓ Useful power
    - ✓ Motor torque
    - ✓ Counter-electromotive force
    - ✓ Rotor Joule decrease
    - ✓ Efficiency
- **Plotting of properties based on motor measurements:**
  - Rotation speed as a function of the field system current
  - Rotation speed as a function of the rotor current
  - Efficiency as a function of the rotor current
  - Torque as a function of the rotor current
  - Power consumption as a function of the rotor current
- **Analysis of results and conclusion**





PACK-DC1      PACK-DC2

Delivered with teaching resources  
Student booklet: theoretical studies and practical works  
Teacher booklet: with correct versions of the practical works

## STUDYING THE 1.5KW DC MOTOR AND 3-PHASE ALTERNATOR

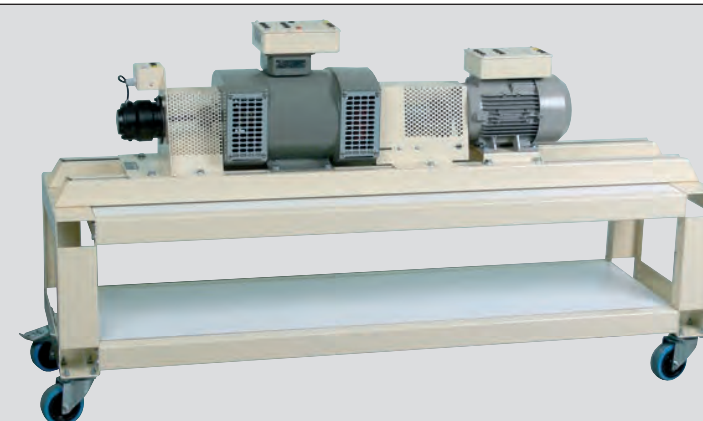
### DESCRIPTION OF THE 20 ITEMS INCLUDED PACK-DC2 REFERENCE



DC motor Ref. CC20 - Qty 1	3-phase alternator Ref. MSM20 - Qty 1	Stand on wheels Ref. CTC - Qty 1 Guide rails Ref. RGC - Qty 1
Rotary torque sensor Ref. CR2-V2 - Qty 1	DC tachogenerator Ref. DYTA2 - Qty 1	
 DC variable supply Ref. COMPAK40 - Qty 1	 2000W Resistive load Ref. RHP20 - Qty 1	 3-phase wattmeter Ref. W17 - Qty 1
 Synchronoscope Ref. CHR3 - Qty 1	 AC/DC Power supply Ref. ISOSEC1 - Qty 1	 Magnetolectric voltmeter Ref. V1001 - Qty 2
 Digital wattmeter Ref. WATELEC - Qty 1	 Measurement of mechanical quantities Ref. MECAWATT2 - Qty 1	 Rheostat Ref. ECO2-106 - Qty 1
 Set of 67 safety leads Ref. 400S - Qty 1 set	 20A magnetolectric Ammeter Ref. A11 - Qty 2	 Rheostat Ref. ECO1-470 - Qty 1

ref. PACK-DC2  
ALSO AVAILABLE IN 300W. CONSULT US.

### TUTORIAL WITH PACK-DC2

- **STUDY OF THE DC MOTOR**
  - **Preliminary study**
    - Reading of the specifications plate, calculation of the torque & nominal efficiency
    - Calculation of the starting torque
    - Calculation method for determining the resistance value of the starting rheostat
  - **Study of the motor's operation when unloaded, when loaded & when overloaded**
    - Theoretical reminders of the mathematical formulae applying to a DC motor.
    - Understanding & undertaking motor wiring with measuring devices.
    - Creation of a table containing calculations and measurements of electrical and mechanical quantities at various points of the motor load:
      - Current & Power consumption of field system/in the rotor
      - Rotation speed
      - Useful power
      - Motor torque
      - Counter-electromotive force
      - Rotor Joule decrease
      - Efficiency
  - **Plotting of properties based on motor measurements such as:**
    - Rotation speed as a function of the field system current
    - Rotation speed as a function of the rotor current
    - Efficiency as a function of the rotor current
    - Torque as a function of the rotor current
    - Power consumption as a function of the rotor current
  - **Results of powers**
    - Calculation of losses motor unloaded
    - Results of power in nominal functioning
  - **Analysis of results and conclusion**
- 
- **STUDY OF THE ALTERNATOR**
  - **Preliminary study**
    - Reading of the specifications plate, calculation of the torque & nominal efficiency
  - **Study of alternator operation with no load, with a load and with an overload, using a resistive load:**
    - Theoretical reminders of the mathematical formulae which apply to the alternator.
    - Understanding and undertaking alternator wiring with measuring devices.
    - Measurement and plotting of the properties of the magnetic circuit's hysteresis cycle.
    - Creation of a table containing calculations and measurements of electrical and mechanical quantities at various points of the motor load
    - Plotting the properties of the alternator's load: voltage as a function of the supplied current
    - Calculation of the voltage decrease as a function of the load
  - **Study of the operation of the synchronised alternator on the public network**
    - Understanding and undertaking alternator wiring on the network.
    - Use of the synchronoscope with its various displays
    - Synchronisation on the mains network
  - **Results of powers**
    - Calculation of losses motor unloaded
    - Results of power in nominal functioning
  - **Analysis of results and conclusion**

## HYPERSYNCHRONOUS STUDY SET



**3-phase asynchronous motor**  
Ref. MAS22 - Qty 2  
230/400 VAC- 1,5kW  
with housings

**Stand on wheels**  
Ref. CTA - Qty 1  
**Guide rails**  
Ref. RGA - Qty 1



**Display unit of the power factor**  
Ref. PSY-C - Qty 1  
Indicates from 0.5 inductive to 0.5 capacitive with "1" vertical in the center of the dial.



**Display unit of the central zero power**  
Ref. PSY-W - Qty 1  
Indicates from -1.5kW to 1.5kW with the vertical zero in the center of the dial.



**Speed controller**  
Ref. ACVAR5 - Qty 1  
Mains single-phase 230VAC,  
output 3 x 230VAC- 1.5KW



**1 Capacitive load bank**  
Ref. CH20 - Qty 1  
Widely sized



**Set of 47 safety leads**  
Ref. 400S - Qty 1 set

**1 switching case**  
For an easy synchronization on the national electrical network

An asynchronous motor can convert mechanical energy into electrical energy. To perform this conversion, it has to be driven above the synchronous speed. PACK-HYPER is a set of 2 asynchronous motors mounted on the same axis of rotation with accessories to study hypersynchronous behaviour. The speed controller drives the first motor above its synchronous speed so that the second becomes a three-phase generator. A central zero wattmeter indicates the direction of the electrical energy consumed or fed in the case of feeding into the grid. A central COS φ phase-meter demonstrates the change of COS φ following the addition of capacitors or speed variation.

### EDUCATIONAL OBJECTIVES

- Studying the hyposynchronous and hypersynchronous operations of an asynchronous motor.
- Studying the effect of a battery of capacitors on the COSφ value.
- Studying synchronisation with the national grid.
- Studying energy use at an isolated site.
- Calculating the outputs of an energy production system.
- Using a clamp ammeter.

### TEACHING RESOURCES STUDENT & TEACHER

### Proposed practical work

- Procedure of synchronisation with the national grid.
- Hyposynchronous and hypersynchronous measurement.
- Reading COS φ using a battery of capacitors and consequences.
- Plotting of the electrical characteristics of the energy production system.
- Calculation of the overall output.
- Study of the operation at an isolated site.

### ref. PACK-HYPER

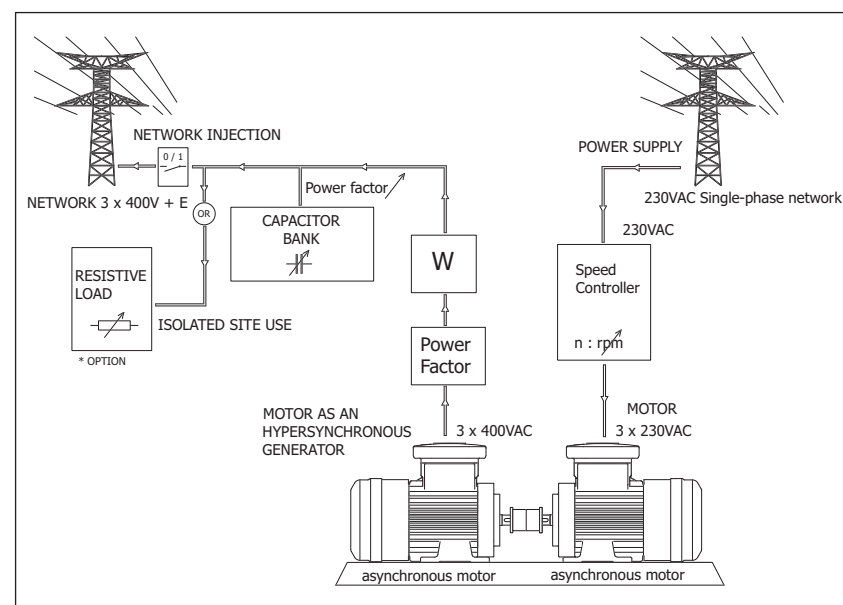

**OPTION**  
**2000W Resistive load**  
Ref. RHP20 - Qty 1  
(features P. 72)



**AVAILABLE-MODULAR SOLUTION**

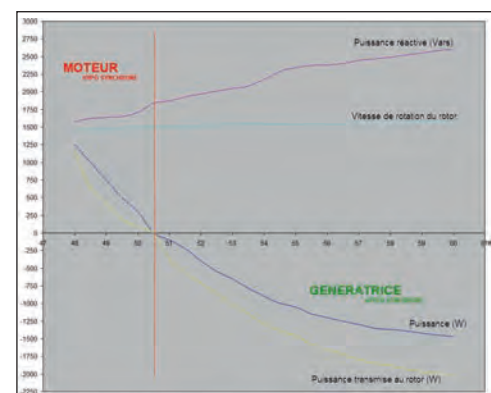

## PROTECTIVE COVERS FOR MACHINE COUPLING



ref. BT80



ref. CART812



ref. CART80



ref. VS10

REF	Power	Protection length	Height	Specifications
CART300W/80	300W	80mm	125mm	Intermediate housing between 2 machines
CART90	300W	95mm	125mm	Intermediate housing between 2 machines
BT300	300W	60mm	125mm	Housing for unused end of shaft
BT80	1500W	80mm	185mm	Housing for unused end of shaft
CART80	1500/3000W	80mm	185mm	Intermediate housing between 2 machines
CART120	1500/3000W	126mm	185mm	Intermediate housing between 2 machines
CART140	1500/3000W	140mm	185mm	Intermediate housing between 2 machines
CART812	1500/3000W	from 80 to 115mm	185mm	Length-adjustable intermediate housing
VS300	300W	/	/	Screw + Washers + Special Nut
VS10	1500/3000W	/	/	Screw + Washers + Slide Nut

## REPLACEMENT COUPLINGS

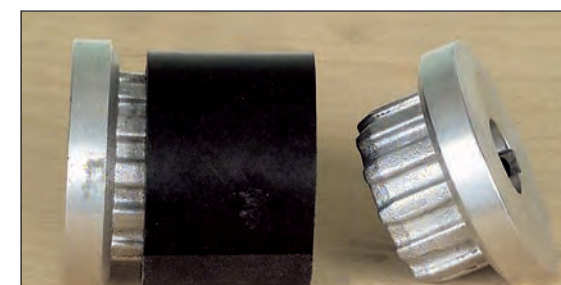

REF. ACC1-19 + AC43 + ACC1-19

These are spare parts, the rotating machines are fitted with their original couplings. A complete set of spare part couplings comprises 2 metal hubs and a rubber sleeve (3 references in total)

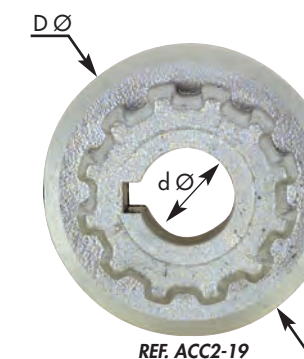

REF. ACC2-19

These are spare parts, as the rotating machines are fitted with their original couplings.

REF	Power	Specification	d Ø	D Ø
ACC1-14	300W	HUB	14mm	42mm
ACC1-17	300W	HUB	17mm	42mm
ACC1-19	300W	HUB	19mm	42mm
AC-43	300W	SLEEVE	sleeve	45mm
ACC2-19	1500W	HUB	19mm	52mm
ACC2-24	1500W	HUB	24mm	52mm
AC-56	1500W	SLEEVE	sleeve	56mm
ACC3-19	3000W	HUB	19mm	69mm
ACC3-24	3000W	HUB	24mm	69mm
ACC3-28	3000W	HUB	28mm	69mm
AC-66	3000W	SLEEVE	sleeve	74mm

**RANGE 90W - 230V & 24V ROTARY MACHINES & COMPATIBLE ITEMS**

**DC SERIES WOUND MOTOR**

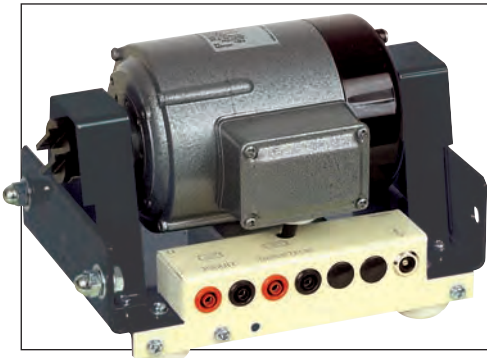

- Voltage : 230V
- Current : 1,2A
- Dim. 210 x 150 x 150mm

ref. SE90

**DC SHUNT MOTOR SEPARATE WINDING**



- Dim. 210 x 150 x 150mm
- Works as motor or generator
- Induced Voltage: 230V/0.75A
- Field excitation voltage: 230V/90mA

ref. SH90-220

- Induced Voltage: 24V/6.4A
- Field excitation voltage: 24V/0.62mA

ref. SH90-24

Built-In tachogenerator (See text box)

**DC MOTOR PERMANENT MAGNET**



- Dim. 210 x 150 x 150mm
- Induced Voltage: 230V/0,6A

ref. AI90-220

- Induced Voltage: 24V/5,5A

ref. AI90-24

Built-In tachogenerator (See text box)

**DC GENERATOR SHUNT ON ROCKING STAND**

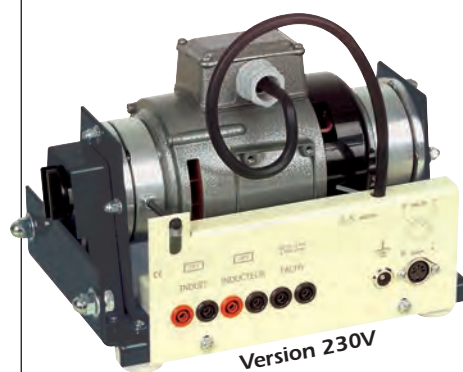

- Dim. 210 x 150 x 150mm
- Induced Voltage: 180V/0,5A
- Field excitation voltage: 230V/90mA

ref. GE90-220

- Induced Voltage: 24V/6.4A
- Field excitation voltage: 24V/0.56mA

ref. GE90-24

Built-In tachogenerator (See text box)

Built-In Torque sensor (See text box)

**DC SPEED CONTROLLERS**



For 230V

ref. VAR126P

For 24V

ref. VAR24D

compatible

**POWER SUPPLY FOR 230V**

Adjustable between 0 and 240V DC or AC, this power with voltmeter and ammeter delivers a permanent 3A current. It is protected by a thermal magnetic circuit breaker. Protection of the user is done by separation of circuits. Filtering is done by capacitors.



ref. ISOSEC1

**INERTIA WHEEL**

The inertia wheel VOL90 connects to all the machines and can be also inserted between two machines

- Mass of wheel 5.5kg.
- Moment of inertia = 0.011kgm<sup>2</sup>

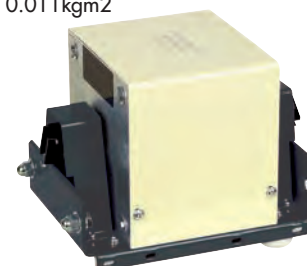

ref. VOL90

**POWER SUPPLY FOR 24V**



Adjustable voltage 0 to 30V  
Adjustable current 0 to 6A  
Protected against overload and short circuit

ref. GPR3060D

**TACHYMETER**



TAC-90 displays in rpm the rotary speed of machines SH90, AI90, GE90 by converting the frequency of the tachogenerator into a voltage. Display 3 1/2 digits. Analog output 0-10V 10 mA max.

ref. TAC90

compatible

**TACHOGENERATOR BUILT-INTO THE SH90 & AI90 & GE90**



The machines SH90, AI90 & GE90 are equipped with a tachogenerator. It's an alternating tachometer which provides a voltage & a frequency proportional to the speed of rotation.

- frequency: 200Hz at 1000rpm
- Voltage: 5VAC at 1000rpm

**3-PHASE ASYNCHRONOUS SQUIRREL CAGE MOTOR**

- Dim. 210 x 150 x 150mm
- Induced voltage separate windings 230-400V / 0.2-0.36A by phase
- Associated converter: VAR90R

ref. TR90-220

- Induced voltage separate windings 24-42V / 6.6A-3.8A by phase
- Associated converter: VAR24S

ref. TR90-24



compatible

**SPEED CONTROLLERS**

The three-phase motors can be controlled by this converter from 10 to 150% of their normal operating speed.

3 x 230V on terminals

ref. VAR90R

3 x 24V on terminals

ref. VAR24S



**SINGLE-PHASE CAPACITOR MOTOR**

- Dim. 210 x 150 x 150mm
- Voltage: 230V
- Current: 0.8A
- Capacitor: permanent

ref. MO90-220

- Voltage: 24V
- Current: 7.6A
- Capacitor: permanent

ref. MO90-24

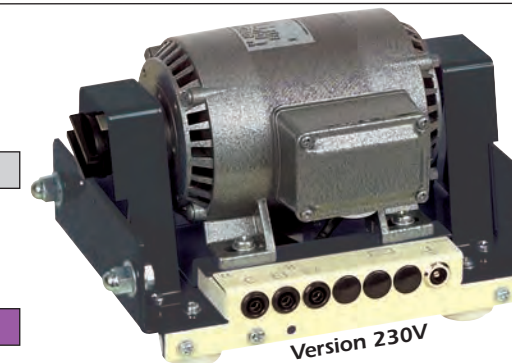

**DIGITAL TORQUE METER**

It displays via a DIN plug, the strength of torque of generator GE90 and brake FR90.



Analog output: 0 to 10V 2mA max.

ref. GAMA96

compatible

**TORQUE SENSOR BUILT-INTO THE GE90 & FR90**



The machines GE90 & FR90 are equipped with a torque sensor. It's an aluminium construction equipped with a strain gauge in Wheatstone bridge. Sensitivity: 10mV/Nm Maximum stress: 1Nm Supply: 6V DC

compatible

**POWDER BRAKE**

- Break voltage: 0-10V DC
- Current: 0-60mA locking at 60mA
- Dim. 210 x 150 x 150mm

Built-In Torque sensor (See text box)

ref. FR90

ref. FR-DYN90

FR-DYN90 = FR90 but with DC tachogenerator for data acquisition 10V/1000rpm

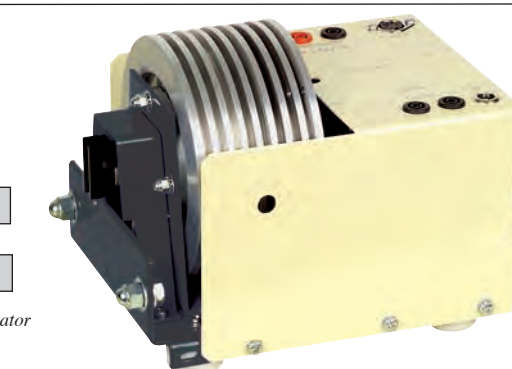

RORTARY MACHINES 1500RPM

RANGE 300W

3-PHASE SQUIRREL CAGE INDUCTION MOTOR

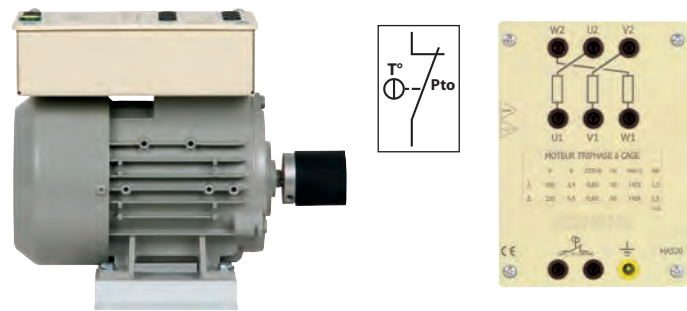

These engines work as well with a speed variator as directly connected to a 3-phase supply.

REF	U (V)	I (A)	H	B	L	Weight
MAS12	230/400V	1.5/0.9	90	172	235	8.2kg
MAS42	400V/690V	0.9/0.5	90	172	235	8.2kg

3-PHASE SYNCHRONOUS MACHINE

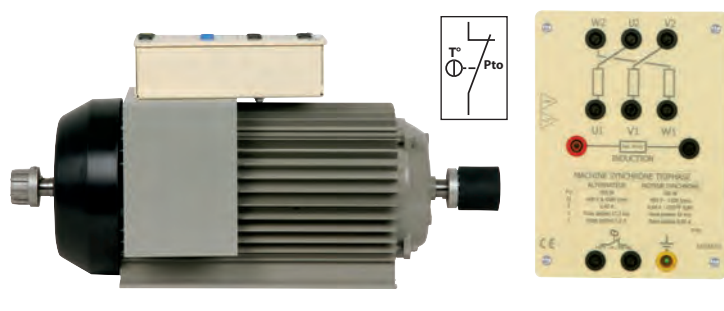

Works as a synchronous motor and 3-phase alternator. Equipped with LEBLANC poles for the mains network synchronization.

REF	U (V)	H	B	L	Weight
MSM10	230/400V	90	172	470	18kg

3-PHASE ASYNCHRONOUS SLIP RING INDUCTION MOTOR

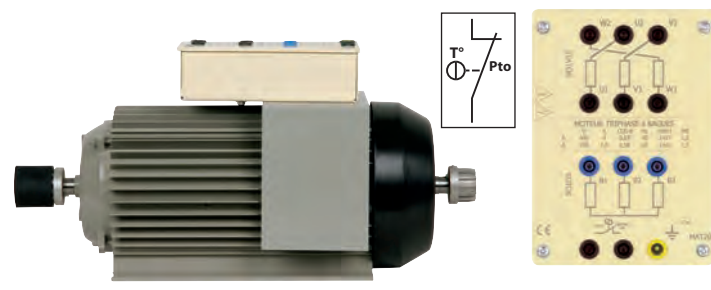

REF	U (V)	I (A)	H	B	L	Weight
MAT10	230/400V	3.1/1.8	90	172	470	18kg
MAT10-C1	similar than MAT10 with 1024 points encoder.					

SINGLE-PHASE MOTOR WITH 2 CAPACITORS

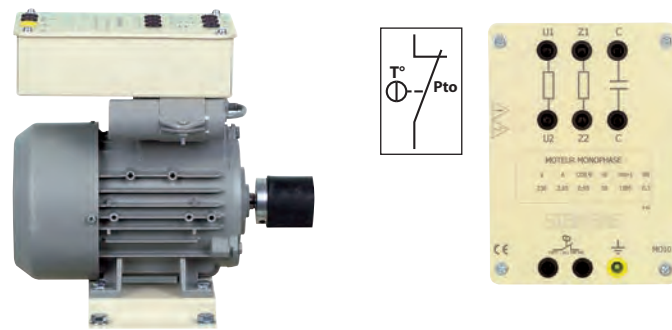

2 capacitors, 1 starting and 1 running

REF	U (V)	I (A)	H	B	L	Weight
MO10	230V	2.6A	90	172	295	9kg

3-PHASE ASYNCHRONOUS 2-SPEED MOTOR (AC)

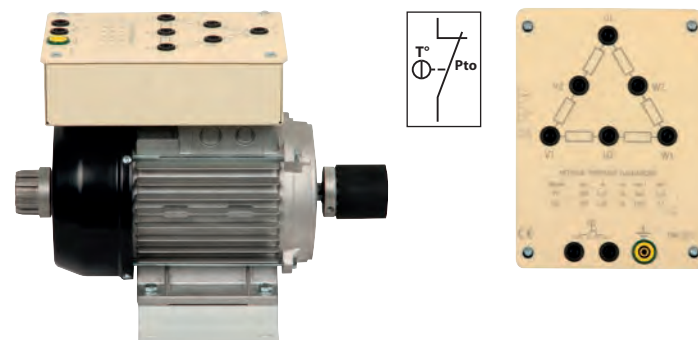

1 coil winding motor with 4/8 pole Dalhander coupling for quadratic resistive torque machines

REF	n in RPM	U (V)	I (A)	P (W)	H	B	L	Weight
DAL10	1500/750	400/400	1.1/1	300/150	90	172	275	7,3kg

3-PHASE RELUCTANCE SYNCHRONOUS MOTOR (AC)

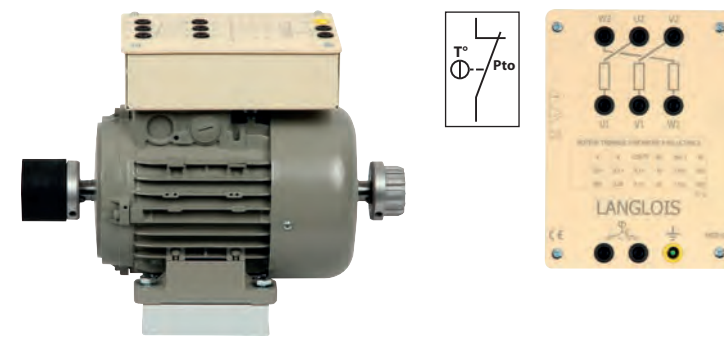

This type of motor works as well on frequency converter as on 50Hz direct mains.

REF	U (V)	I (A)	P (W)	H	B	L	Weight
MSR10	400V	2A	300W	90	172	320	12.1kg

RORTARY MACHINES.

1500RPM

RANGE 300W

POWDER BRAKE

POWDER BRAKE PRINCIPLE

The DC current injected into the brake coil creates a field which causes the magnetic powder placed in the air gap to agglomerate. The braking torque is proportional to the field current alone; in particular it is independent of the speed of rotation. Waste heat is eliminated by natural ventilation.

A protection cuts the excitation in case of overheating of the brake. An externally accessible fuse protects the brake coil in the event of overvoltage. The torque measurement requires a rotary sensor to be positioned either on the left or on the right. Maximum rotation speed 1800 rpm.

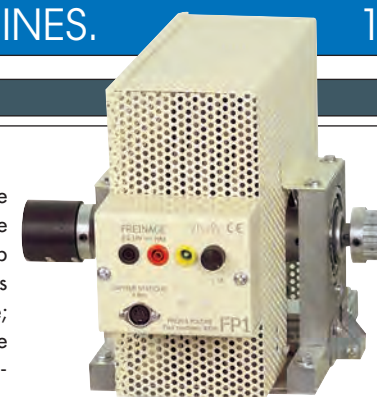

REF	FP1
Voltage/Current max for blocking	2V / 0,1A
Max torque	35Nm
H / B / L in mm	90x172x240
Weight	18kg
Ventilation	Fanless

POLYEXCITATION (COMPOUND) GENERATOR

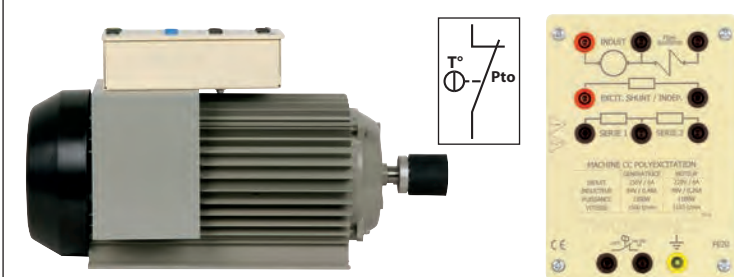

Designed to be high-performance generator (characteristics below), this machine also works as a motor.

REF	U (V)	I (A)	H	B	L	Weight
PE10	220V	2A	90	172	420	20kg

PERMANENT MAGNET SYNCHRONOUS 3-PHASE MOTOR (AC)

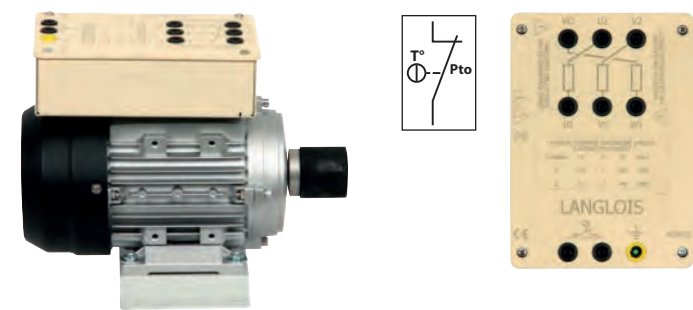

High efficiency motor, requires a control by speed variator.

REF	n (RPM)	U (V)	I (A)	f (Hz)	P (W)
MSAP10	1000/1500	375/445	1/1	50 / 75	300/440
H	B	L	Weight		
90	172	270	4,1kg		

POLYEXCITATION (COMPOUND) MOTOR

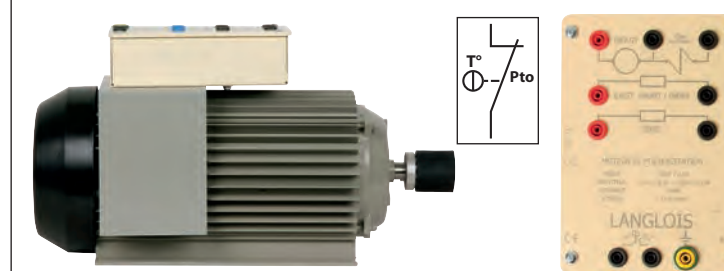

Designed to be high-performance motor (characteristics below), this machine also works as a generator.

REF	U (V)	I (A)	H	B	L	Weight
PM10	220V	2.3A	90	172	420	25kg

SHUNT / SEPARATED DC GENERATOR

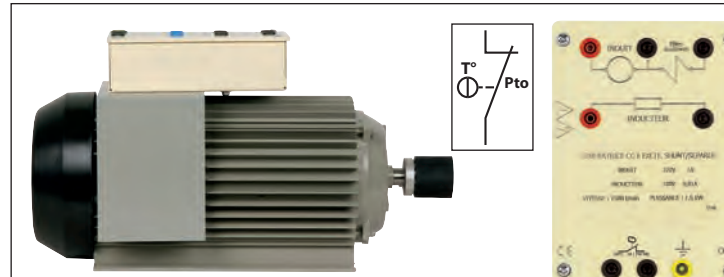

Designed for a didactic use.

REF	U (V)	I (A)	H	B	L	Weight
CG10	220V	2A	90	172	420	20kg

SHUNT / SEPARATED DC MOTOR 220/220V

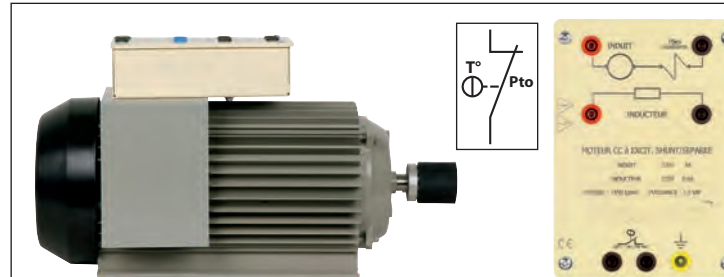

This engine works as well with a speed variator as directly connected to a DC supply.

REF	U (V)	I (A)	H	B	L	Weight
CC10	220/220V	2A sous 230V	90	172	420	21kg

Each machine is equipped with a binary temperature sensor with a contact that can be inserted into a control circuit.

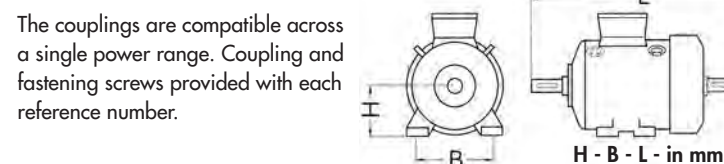

ROTARY MACHINES 1500RPM

RANGE 1500W

3-PHASE SQUIRREL CAGE INDUCTION MOTOR

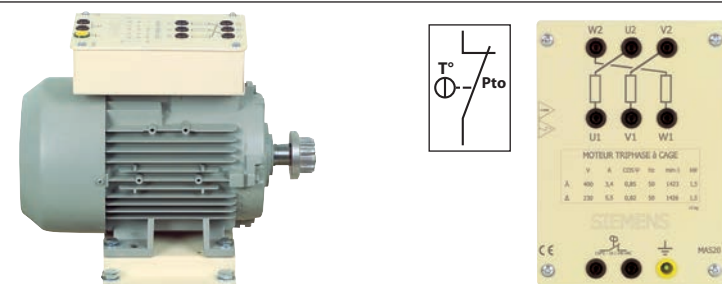

These engines work as well with a speed variator as directly connected to a 3-phase supply.

REF	U (V)	I (A)	H	B	L	Weight
MAS22*	230/400V	5.7/3.3	112	190	355	20kg
MAS52*	400V/690V	3.3/1.9	112	190	355	20kg

\*IE2

STAR/DELTA STARTER

Manual STAR/DELTA starter into a safety box

ref. CO-ET-8A



3-PHASE ASYNCHRONOUS SLIP RING INDUCTION MOTOR

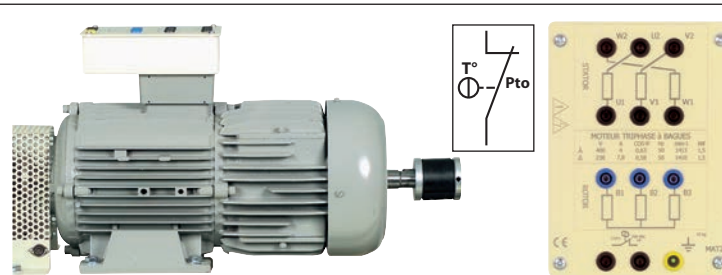

REF	U (V)	I (A)	H	B	L	Weight
MAT20	230/400V	6.4 / 3.7	112	190	665	43kg
MAT20-C1	similar than MAT20 with 1024 points encoder.					

3-PHASE ASYNCHRONOUS 2-SPEED MOTOR (AC)

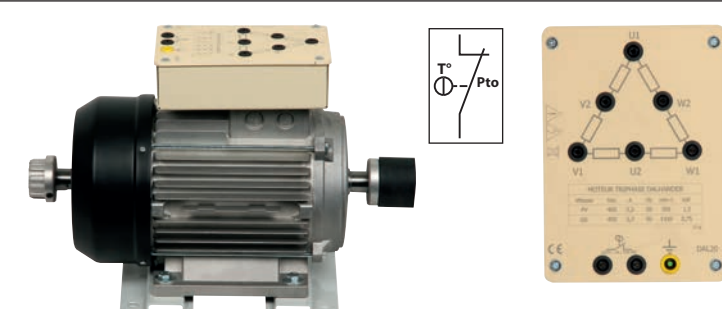

1 coil winding motor with 4/8 pole Dalhander coupling for quadratic resistive torque machines

REF	n in RPM	U (V)	I (A)	P (W)	H	B	L	Weight
DAL20	1500/750	400/400	3,3/2,7	1500/750	112	190	410	25kg

3-PHASE SYNCHRONOUS MACHINE

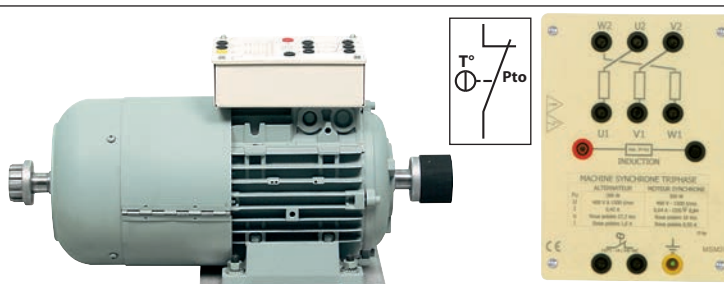

Works as a synchronous motor and 3-phase alternator. Equipped with LEBLANC poles for mains network synchronization.

REF	U (V)	H	B	L	Weight
MSM20	230/400V	112	190	470	48kg

SAFETY STARTER RHEOSTAT

Safety starter rheostat for high powerful slip ring machines

ref. REDA12

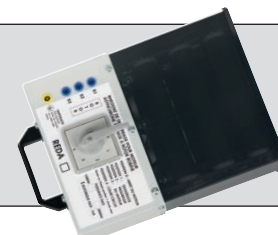

SINGLE PHASE MOTOR WITH 2 CAPACITORS

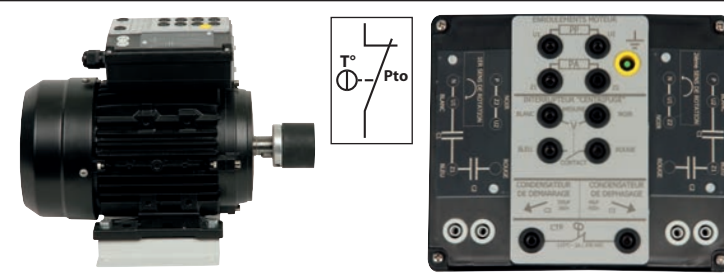

2 capacitors, 1 starting and 1 running

REF	U (V)	I (A)	H	B	L	Weight
MO20	230V	9A	112	190	350	17kg

3-PHASE ASYNCHRONOUS CAGE MOTOR WITH VECTORIAL CONTROL

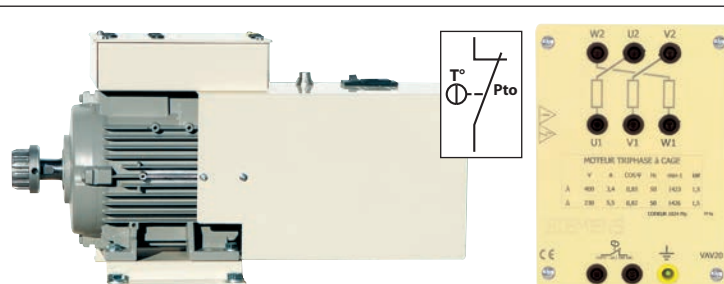

Fitted with a 1024 pts encoder and a forced ventilation to run at slow speed

REF	U (V)	I (A)	H	B	L	Weight
VAV20	230/400V	5.9 / 3.4	112	190	580	24kg
VAV50	400/690V	3.4 / 1.95	112	190	580	24kg

ROTARY MACHINES 1500RPM

RANGE 1500W

SHUNT / SEPARATED DC MOTOR 220/220V

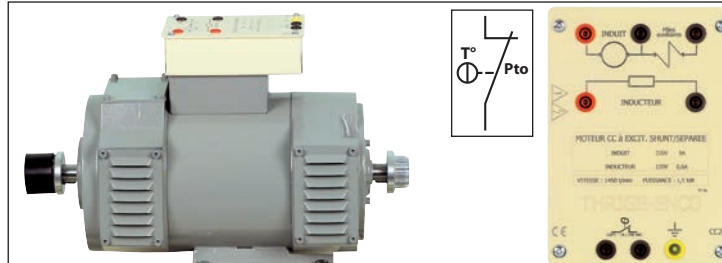

This engine works as well with a DC speed variator as directly connected to a DC supply.

REF	U (V)	I (A)	H	B	L	Weight
CC20	220/220V	9A with 230V	112	190	510	51kg

POLYEXCITATION COMPOUND DC MOTOR

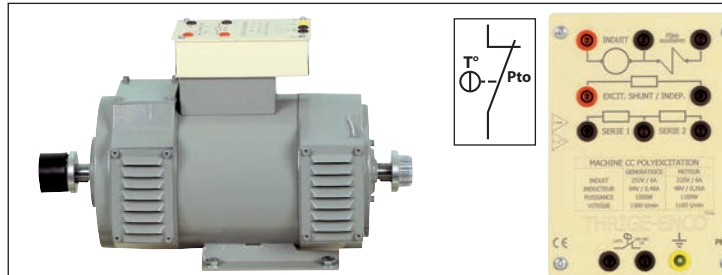

Designed to be high-performance motor (characteristics below), this machine also works as a generator.

REF	U (V)	I (A)	H	B	L	Weight
PM20	220V	7.6A	112	190	510	253g

STARTER RHEOSTAT

Safety starter rheostat for high powerful DC machines.

ref. REDA34



SHUNT / SEPARATED DC GENERATOR

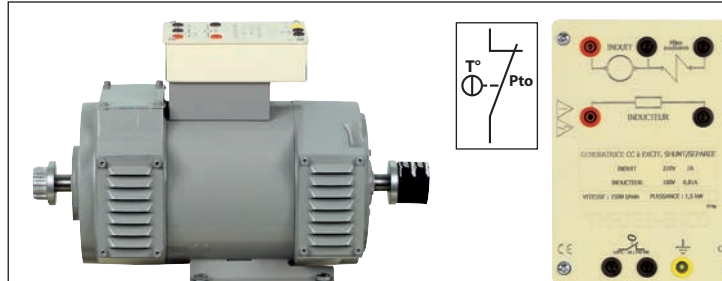

Designed for a didactic use.

REF	U (V)	I (A)	H	B	L	Weight
CG20	240V	7A	112	190	510	53kg

The couplings are compatible across a single power range. Coupling and fastening screws provided with each reference number.

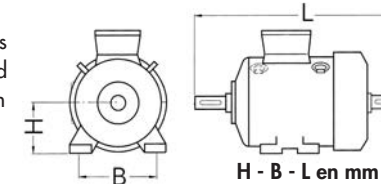

POLYEXCITATION COMPOUND DC GENERATOR

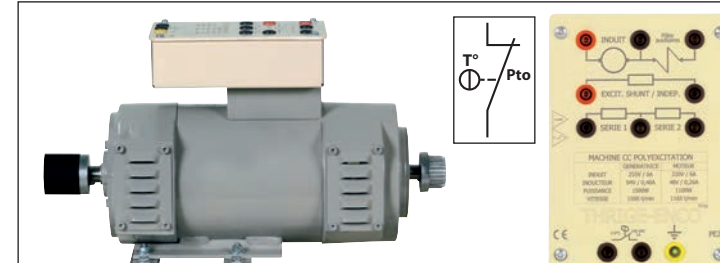

Designed to be high-performance generator (characteristics below), this machine also works as a motor.

REF	U (V)	I (A)	H	B	L	Weight
PE20	255V	6A	112	190	510	53kg

POWDER BRAKE

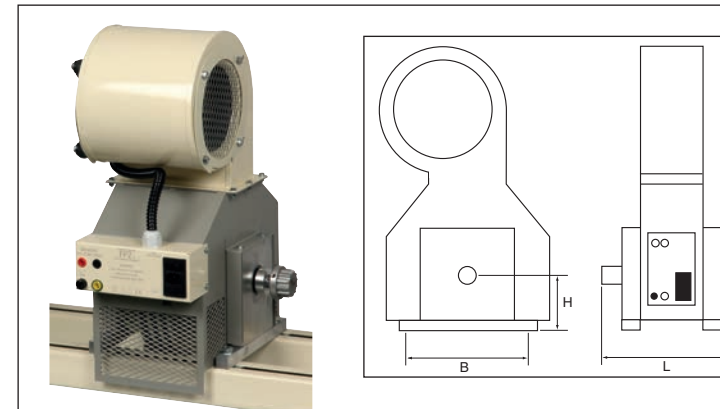

POWDER BRAKE PRINCIPLE

The DC current injected into the brake coil creates a field which causes the magnetic powder placed in the air gap to agglomerate. The braking torque is proportional to the field current alone; in particular it is independent of the speed of rotation. Waste heat is eliminated by forced ventilation. A circuit breaker cuts the field current in the event of the brake overheating.

REF	FP2
Voltage/Current max for blocking	10V / 0.5A
Max torque	65Nm
H / B / L in mm	112 x 190 x 356
Weight	43kg
Ventilation	Fan

Each machine is equipped with a binary temperature sensor with a contact that can be inserted into a control circuit.

TACHOMETER FOR 1024PTS ENCODER SYNCHRONOSCOPE



ref. VICOD

ref. CHR3

ROTARY MACHINES 1500RPM

RANGE 3000W

3-PHASE SQUIRREL CAGE INDUCTION MOTOR

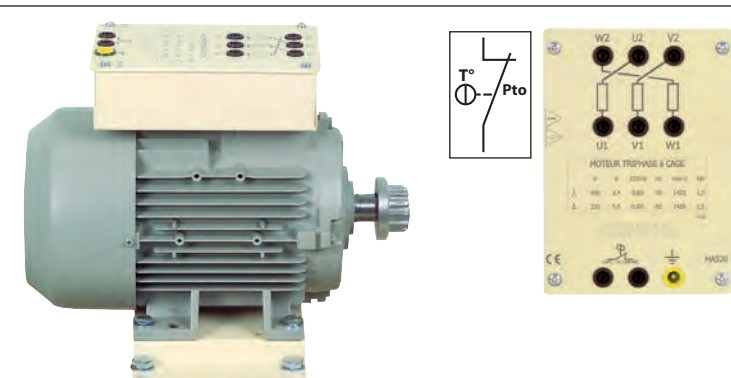

These engines work as well with a speed variator as directly connected to a 3-phase supply.

REF	U (V)	I (A)	H	B	L	Weight
MAS32*	230/400V	10.6/6.1	132	216	445	28kg
MAS62*	400V/690V	6.1/3.5	132	216	445	28kg

\*IE2

3-PHASE SYNCHRONOUS MACHINE

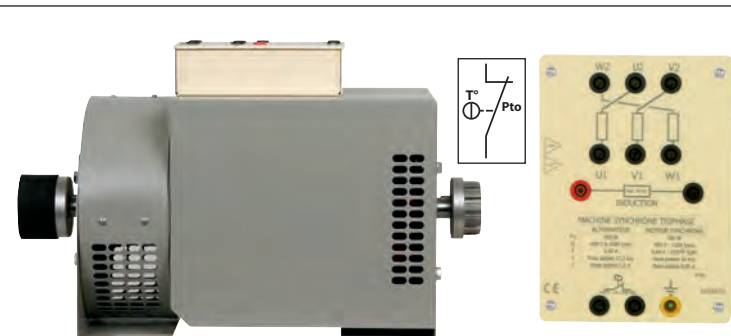

Works as a synchronous motor and a 3-phase alternator. Equipped with LEBLANC poles for mains network synchronization.

REF	U en V	H	B	L	Masse
MSM30	230/400V	132	216	490	49kg
MSM30-C1	similar than MSM300 with 1024 points encoder.				

STAR/DELTA STARTER

Manual STAR/DELTA starter into a safety box

ref. CO-ET-8A



SYNCHRONOSCOPE

Safety laboratory synchronoscope 16A - 400V max.

ref. CHR3



3-PHASE ASYNCHRONOUS SLIP RING INDUCTION MOTOR

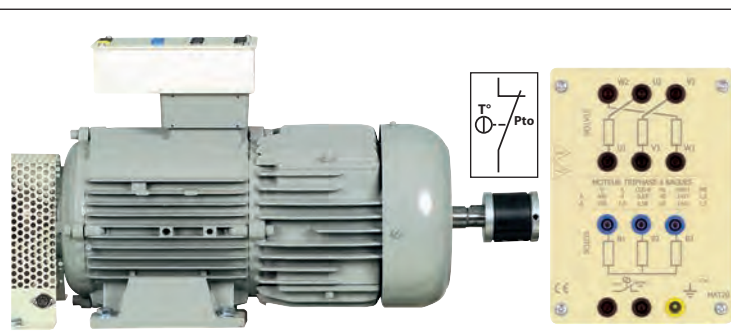

REF	U (V)	I (A)	H	B	L	Weight
MAT30	230/400V	13.2 / 7.5	132	216	685	70kg
MAT30-C1	similar than MAT30 with 1024 points encoder.					

3-PHASE ASYNCHRONOUS CAGE MOTOR WITH VECTORIAL CONTROL

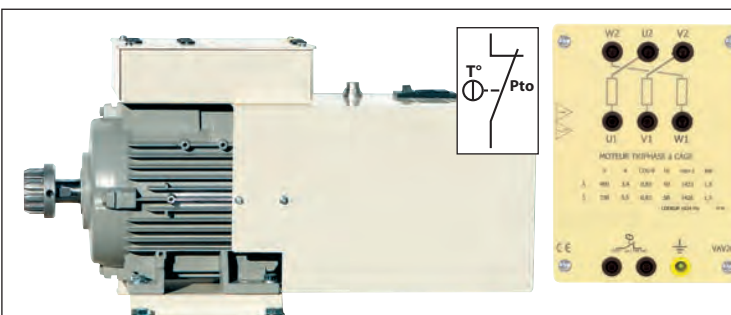

Fitted with a 1024 pts encoder and a forced ventilation to run at a slow speed.

REF	U (V)	I (A)	H	B	L	Weight
VAV30	230/400V	10.6 / 6.7	132	216	620	28kg
VAV60	400/690	6.1 / 3.5	132	216	620	28kg

Each machine is equipped with a binary temperature sensor with a contact that can be inserted into a control circuit.

The couplings are compatible across a single power range. Coupling and fastening screws provided with each reference number.

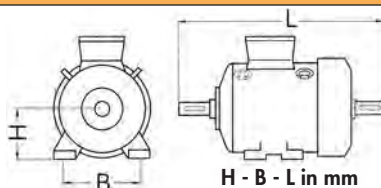

SAFETY STARTER RHEOSTAT

Safety starter rheostat for high powerful slip ring machines.

ref. REDA12



ROTARY MACHINES 1500RPM

RANGE 3000W

SHUNT / SEPARATED DC MOTOR 220/220V

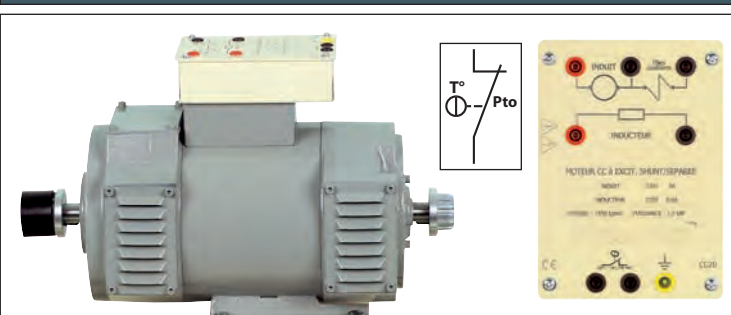

This engine works as well with a speed variator as directly on a DC supply.

REF	U (V)	I (A)	H	B	L	Weight
CC30	Multitensions	16.5A	132	216	550	80kg
	with 220V					

POLYEXCITATION COMPOUND DC MOTOR

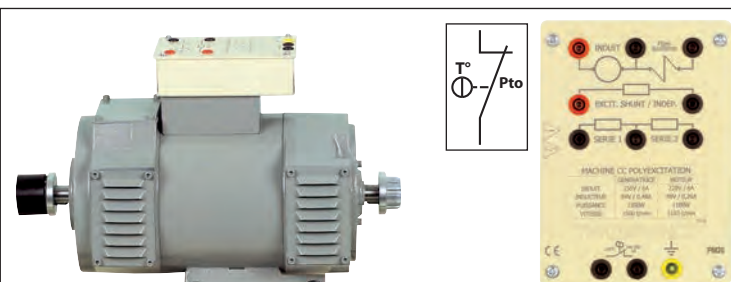

Designed to be high-performance motor (characteristics below), this machine also works as a generator.

REF	U (V)	I (A)	H	B	L	Weight
PM30	220V	17.9A	132	216	570	83kg

SAFETY STARTER RHEOSTAT

Safety starter rheostat for high powerful DC machines.

ref. REDA34



SHUNT / SEPARATED DC GENERATOR

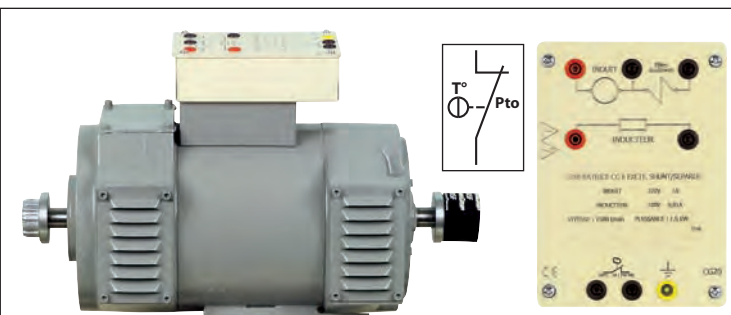

Designed for a didactic use.

REF	U (V)	I (A)	H	B	L	Weight
CG30	220V	14.2A	132	216	570	83kg

POLYEXCITATION COMPOUND DC GENERATOR

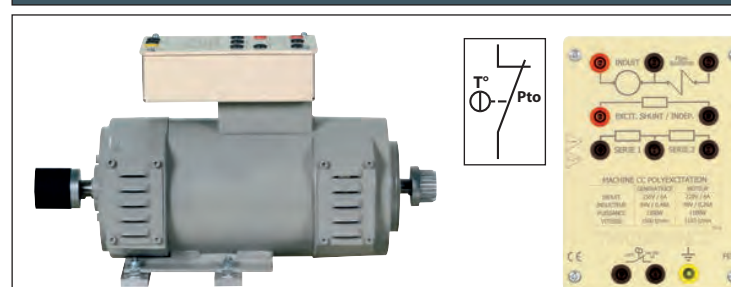

Designed to be high-performance generator (characteristics below), this machine also works as a motor.

REF	U (V)	I (A)	H	B	L	Weight
PE30	270V	13.6A	132	216	570	83kg

POWDER BRAKE REINFORCED

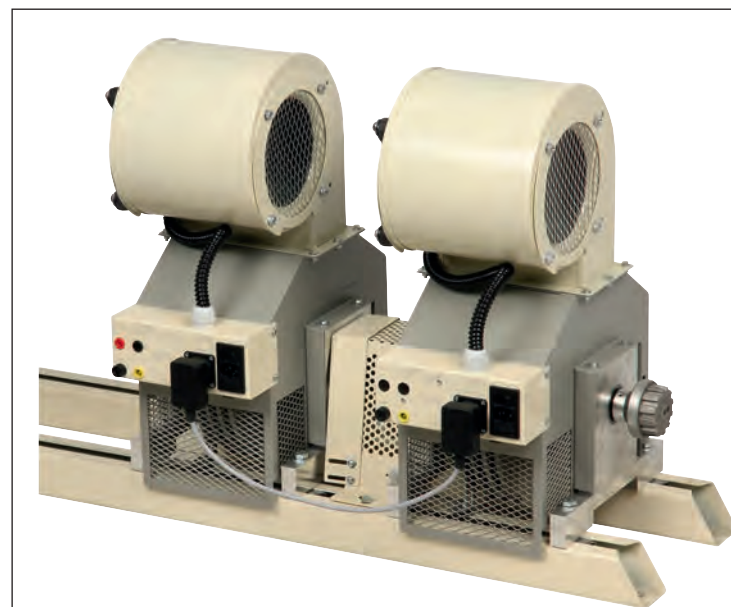

As the powder brakes of the other ranges, a simple DC current under a low voltage around 14V generates a constant braking torque for all the speeds between 0 to 1500 rpm.

This reinforced model is composed of 2 independent units and linked together by the rotating shaft. Thanks to this power distribution, dissipation of energy is most effective. An automatic monitoring avoid the functioning of only one unit or if the ventilation is not complete.

The measure of the torque required a rotating unit (see page 58) which needs to be placed indifferently on the left or on the right.

Maximum rotating unit: 1800 rpm

REF	FP332
Voltage/Current max for blocking	14V / 0.8A
Max torque	80Nm
H / B / L in mm	132 x 216 x 720
Weight	86kg
Ventilation (MAINS 230V)	Fan

ACCESSORIES FOR ROTARY MACHINES - ALL RANGES

TORQUE SENSORS

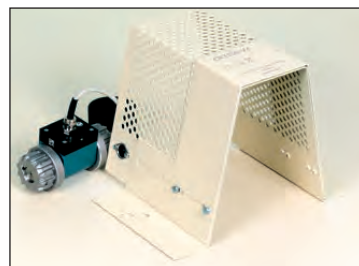

DISPLAYS PAGE 62

BRUSHLESS VERSION

These brushless torque sensors have to be placed between 2 machines and measure the torque sensor V2 and the twist torques and speeds for the version V22. It is equipped with an optical torque so without mechanical wear and maintenance, with a dynamic range allowing to measure some important torque changes and high speeds. The values of starting are so easily measurable.

Torque output signal: 0 to 5V for the measuring span in Nm (0 to -5V according the rotating way).

Maximum rotating speed: 2000 rpm

Sensor supply: between 12 and 28 VDC

\* The use of an inertia wheel + a rotary sensor (CR design) between the motor and the brake gives starting torques which can go to 7 times the operating torque.

Connecting cable and protection casing supplied with all our sensors.

REF	Power	Sensor range	Speed output	L mm	Use with an important inertia
CR1-V2	300W	20 Nm	no	220	Yes
CR1-V22	300W	20 Nm	5V at 2500 rpm	220	Yes
CR2-V2*	1500W	50 Nm	no	220	no*
CR2-V22*	1500W	50 Nm	5V at 2500 rpm	220	no*
CR2-100-V2	1500W	100 Nm	no	220	Yes
CR2-100-V22	1500W	100 Nm	5V at 2500 rpm	220	Yes
CR3-V2*	3000W	50 Nm	no	220	no*
CR3-V22*	3000W	50 Nm	5V at 2500 rpm	220	no*
CR3-100-V2	3000W	100 Nm	no	220	Yes
CR3-100-V22	3000W	100 Nm	5V at 2500 rpm	220	Yes

DC TACHOGENERATORS



These tachogenerators deliver a continuous voltage proportional to the rotating speed. Supplied complete with couplings, housings and screws bolt.

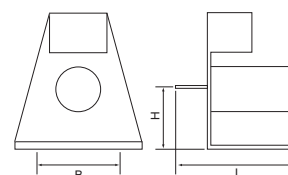

REF	Power	Voltage at 1000 rpm	Connector	H (mm)	B (mm)	L (mm)
DYTA10	300W	10V	Terminals	90	172	170
DYTA2	1500W	10V	Terminals	112	190	130
DYTA3	3000W	10V	Terminals	132	216	130

INERTIA WHEEL

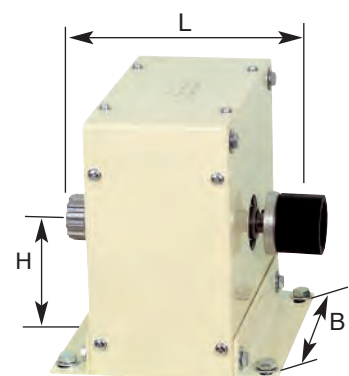

This inertia wheel allows to simulate rotary machines with a high moment of inertia. Supplied with 1 coupling + 1 cover + screws.

REF	VOL1	VOL2	VOL3
<b>For power</b>	<b>300W</b>	<b>1500W</b>	<b>3000W</b>
Inertia	0.025kg/m <sup>2</sup>	0.2kg/m <sup>2</sup>	0.2kg/m <sup>2</sup>
Weight	10kg	39kg	40kg
H	90mm	112mm	132mm
B	172mm	190mm	216mm
L	111mm	220mm	220mm

MOTORS STAND ON WHEELS & GUIDE RAILS

Designed to transport a complete set of machines. 4 wheels, 2 of them with a brake.

REF	Useful Length	Width	Height	Weight
CTA	950mm	470mm	500mm	30kg
CTB	1300mm	470mm	500mm	30kg
CTC	1610mm	470mm	500mm	39kg
CTH	1610mm	470mm	845mm	45kg
CTL	1900mm	470mm	500mm	45kg



Ref. CTH

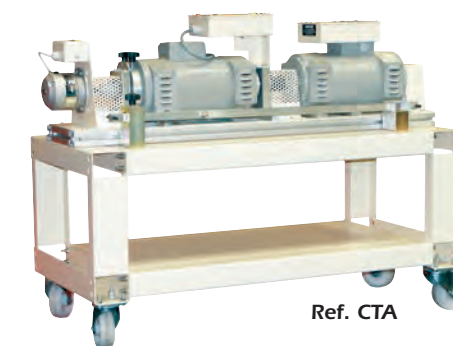

Ref. CTA



Ref. CTC



Handle option

ref. OP-CT

These rails will be used for aligning and fixing the machines constituting of the made up groups according to your own configuration. With each pair of guide rails are included 2 end of shaft protective covers and 1 intermediate housing. All the powder brakes are delivered on guide rails. Total width: 212mm

REF	Power	Overall length	Pitch of rails	Weight
ST10	300W	1100mm	172mm	7kg
STL	300W	1450mm	172mm	8kg
RGA *	1500/3000W	950mm	190/216mm	16kg
RGC	1500/3000W	1600mm	190/216mm	24kg
RGL**	1500/3000W	1900mm	190/216mm	28kg

\*RGA is only compatible with the stand on wheels CTA

\*\*RGL is only compatible with the stand on wheels CTL

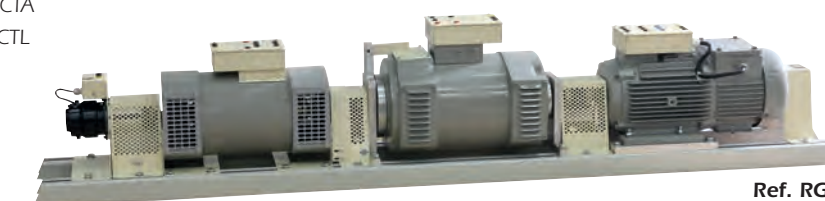

Ref. RGL

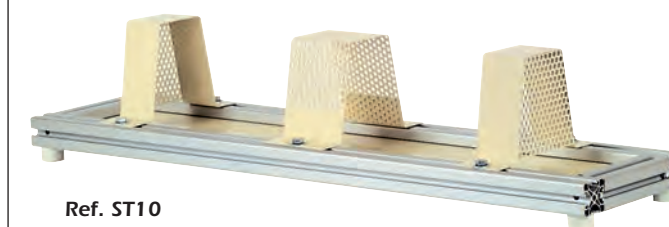

Ref. ST10



Ref. RGC

SPEED - TORQUE - POWER



GENERAL FEATURES

MECAWATT is a display unit for showing 3 mechanical values of torque, speed, and power, with measurements taken on rotating machines using a torque sensor and a tachogenerator. It also includes:

- a manually adjustable energising source for a powder brake, or by external signal
- analog copies of output of the three mechanical values.

Supply : 230V 50Hz, 30VA.

Dimensions : 375 x 80 x 275 mm - 5.8kg.

Height of digits : 14mm (text: 6mm)

DIRECT DISPLAY

- of the mechanical torque in Nm

Brushless torque sensors (-V2)

- of the speed of rotation n in rpm.

Sensors used: any tachometric dynamo of rating 10 - 20 - 60 V at 1000 rpm.

- of the power W

MECAWATT calculates internally the mechanical power  $P_u = M \cdot 2\pi \cdot n / 60$  and directly displays the results in watts.

ref. MECAWATT2

For brushless sensors



FRONT PANEL ADJUSTMENTS

- manual control of braking intensity

ANALOGUE INPUTS AND OUTPUTS

The rear of MECAWATT is equipped with:

- a 0 to 10VDC output at 0 to 500mA manual energising adjustment for a powder brake
- a -5 to +5V\* average torque image output\*\*
- a -5 to +5V\* average speed image output.
- a -5 to +5V\* average power image output.
- \* The sign indicates the direction of rotation of the motor.
- \*\* The integration time constant of the average values is 1s.

MECAWATT is compatible with:

- motors of 90 - 300 - 1500 - 3000W
- rotating torque sensors of 2 to 100 Nm
- tachometric dynamos of 10 - 20 - 60V at 1,000 rpm.

TRMS WATTMETER



ref. WATTELEC

WATTELEC is a digital multimeter with floating inputs simultaneously displaying the 3 electric values: voltage, current and power. WATTELEC measures the TRMS effective values of the U I W measurements, possibly with direct component superimposed. The wide bandwidth of the apparatus allows measurements to be made from DC to 70kHz or on chopped signals (frequency converters, industrial choppers, rectified supplies etc.). The apparatus voltage and current inputs are insulated between each other and relative to earth. WATTELEC measures single phase and balanced three phase powers.

DISPLAY:

Height of digits 14mm (text: 6mm).  
Power ranges are switched automatically.

INPUTS

Voltage inputs: Three floating potential voltage terminals, situated at the rear of the apparatus allowing either the application of an alternating, continuous or composite voltage, or a balanced three phase voltage.

These inputs are electronically protected against over voltages.

Max. voltage: 400Vrms single phase, 700Vrms three phase

Current inputs: Two floating potential current terminals, situated at the rear of the apparatus allowing the application of an alternating, continuous or composite current.  $I_{max} = 20A$ . The current input is protected by a delay fuse, allowing measurements on starting up a motor

RECOPY OUTPUTS

Voltage output: 0 to 10V DC signal for 0 to 1000Vrms entering.

Current output: 0 to 10V DC signal for 0 to 20Arms entering.

Power output: 0 to 10V DC for 0 to 0.2kW - 0 to 2kW - 0 to 20kW; these three ratings are switched automatically.

Important: these three outputs are insulated from the voltage and currents applied to the input terminals of the apparatus.

OTHER CHARACTERISTICS

A switch on the front panel selects the mode single or three-phase.

A reset button allows to reset the displays when the maximum voltage is exceeded. Input and outputs through 4mm safety terminals

Dims: 375 x 80 x 275 mm - 5kg

Supply: 220-240VAC 50Hz 30VA.

Function	U	I	W
Ranges	400Vrms single-phase 700Vrms 3-phase	20Arms	0.2 - 2 - 20kW
Accuracy in % of reading	1% from 0 to 50kHz	2% 0 ~ 20kHz 3% 20 ~ 50kHz	2% 0 ~ 20kHz 3% 20 ~ 30kHz 5% 30 ~ 70kHz
Protection	Electronic breaker	20A delayed fuse	
Impedance	1.5MΩ	<5mΩ	
Recopy outputs	10VDC/1000Vrms	10VDC/20Arms	10VDC/ 0,2kW - 2kW - 20kW

ACQUISITION SYSTEM



ref. PCWATT

PCWATT lets you record and display on a screen mechanical and electrical quantities from the rotating machines (asynchronous motors, synchronous machines, single-phase motors and DC machines). PCWATT is an interface that connects the motor test bench to a PC via a measuring bay composed of at least MECAWATT and WATTELEC\*. The LOGIREAL software delivered with PCWATT lets one display these quantities in real time. During acquisition, the values for voltage, current, power consumed, torque, rotation speed and useful power are shown both as curves and as numeric displays.

After acquisition, PCWATT uses the recorded values to calculate and trace additional mechanical and electrical characteristics, such as slip, efficiency, active power, reactive power, the power factor, and so on.

\* Connection to the PC via USB cable

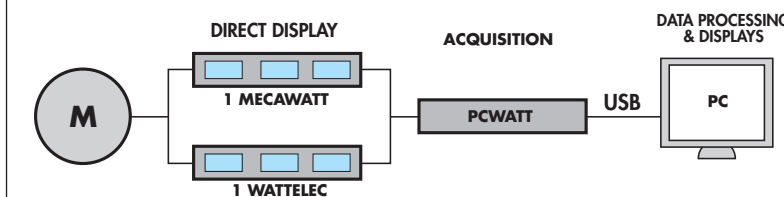

EXAMPLE OF COMPLETE ACQUISITION SOLUTION FOR AC MACHINES STUDY

- 1 PCWATT (with software)
- 1 MECAWATT2
- 1 WATTELEC

LOGYREAL SOFTWARE SUPPLIED WITH PCWATT  
Datasheet on [www.langlois-france.com](http://www.langlois-france.com)

TORQUE SIMULATOR

Datasheet on [www.langlois-france.com](http://www.langlois-france.com)



ref. MECASIM



SPEED & TORQUE DISPLAYS UNITS



Réf.	Torque displays				Speed displays		
	Range	Analogical output of the torque	Compatible with brushless rotary sensor	Brake control	Range	Compatible with DC tachogenerator	Analogical outputs of the speed
GAMA-SB	200,0 Nm	±1V / 10Nm	yes	no	/	/	/
GAMA-SBCF	200,0 Nm	±1V / 10Nm	yes	yes	/	/	/
TAGA-V22B*	200,0 Nm	±1V / 10Nm	yes	no	2000rpm	10, 20, 60V - 1000rpm	±1V / 1000rpm
TACH-V126*	/	/	/	/	2000rpm	10, 20, 60V - 1000rpm	±1V / 1000rpm

\* Compatible with the torque sensor CR\*-V22

CONTROLLABLE POWER SUPPLY FOR BRAKE

GC-420 is a current supply box for powder brake. Current control is devised around a microcontroller circuit providing high precision of the delivered current. Control of the manual brake or by analogue input 0-10V DC.



ref. GC-420

- General informations :**
- Mains power supply 230V AC - 50/60 Hz
  - Max output current 2A.
  - Output load 4-20 ohms
  - Brake control analogue input signal 0-10V DC
  - Dimensions: 240 x 180 x 130 mm

- On the front:**
- A start/stop indicator light.
  - A potentiometer for controlling the set point.
  - A 2-position switch provides control of the stop mode by blocking or disengaging.

- On the rear:**
- Socket/switch/fuse unit assembly for box power supply.
  - 6 terminals for choice of control coupling by potentiometer or by external analogue signal 0-10V DC.
  - 2 terminals for connecting the powder brake.

DISPLAY COMPATIBLE WITH A 1024 PTS ENCODER

2000rpm range compatible with the VAV20 motor.



ref. VICOD

INTERFACE WITHOUT DISPLAYS



The brushless torque sensor is connected to the DIN jack of the **INTER-SB** interface, which is powered by an external 12 to 28V DC power supply (not provided). The 0 to 5V measuring signal (5V for the nominal torque) is the image of the mechanical torque in Nm. A suitably calibrated voltmeter will display the torque directly in Nm.

ref. INTER-SB

DISPLAY AND BRAKE CONTROL UNIT  
SEE REF MECAWATT



AC/AC FREQUENCY CONVERTERS (SPEED VARIATORS)



REFERENCES WITH PRIMARY IN 230V SINGLE-PHASE 50/60Hz  
Output voltages of these variators: three phase 230V - variable frequency.

REF	ACVAR1	ACVAR1-U	ACVAR5	ACVAR5-U	VAR-BOX	VAR-BOX-03
Emergency stop push button	No	Yes	No	Yes	No	No
For motor power	300W	300W	1500W	1500W	1500W	300W
Constant output current	4,4A	4,4A	8A	8A	8A	4,4A
Maximum transient current	5A	5A	12A	12A	12A	5A

REFERENCES WITH PRIMARY IN 400V 3-PHASE 50/60Hz  
Output voltages of these variators: three phase 400V - variable frequency.

REF	ACVAR1-T	ACVAR1-TU	ACVAR5-T	ACVAR5-TU	VAR-BOX-T	ACVAR6
Emergency stop push button	No	Yes	No	Yes	no	no
For motor power	300W	300W	1500W	1500W	1500W	3000W
Constant output current	1.8A	1.8A	4.8A	4.8A	4.8A	7.1A
Maximum transient current	2.3A	2.3A	6.2A	6.2A	6.2A	10.7A

The variators for 300W, 1500W and 3000W machines are frequency converters (at constant V/f) for three-phase asynchronous squirrel-cage induction motors. Converters are supplied ready-to-use for most applications. They include a built-in adjusting terminal (4-digit display, 7 segments) to customize your application by modifying the settings as required and extend the functions. A potentiometer on the front is used to adjust the converter's sampling frequency, and thus the motor rotation speed.

Dimensions: 390 x 280 x 185 mm.

Link jump to choose the rotation's direction, except VAR-BOX.

Supplied with operating/programming instructions, software SoMove and USB lead.



MAIN COMMON FUNCTIONS

- Main configurable functions**
- Up to 8 preselected speeds
  - Rapid stop, freewheel stop, etc.
  - Acceleration/deceleration slope
  - Default reset
  - Sense of rotation choice
- Converter protection and safety systems**
- Short-circuit protection: on outputs, between phases
  - Internal power supply
  - On outputs, between phases and earth
  - Overheating and overcurrent protection
- Motor protection**
- Heat protection built into the converter by calculating I<sup>2</sup>t
  - Phase outage protection

TECHNICAL SPECIFICATIONS OF VAR-BOX

All inputs and outputs of the frequency converter are present on safety sockets 4mm on the front panel:

**Power terminals**

- Mains inputs/outputs to the motor
- Output to a brake resistance (PA/+, PB, PC/-)

**Control terminals**

- Control inputs: 0-10V, 4-20mA, potentiometer (AI3, COM, AOV, AOC, AI1, 10V, AI2)
- Relay contacts outputs (R1A, R1B, R1C, R2A, R2C)
- Logic inputs (24C, LI1, LI2, LI3, LI4, LI5, LI6, LIU)

1 potentiometer 5 kΩ, output on 3 sockets / 1 On/Off switch, output on 2 sockets

STUDY CASE FOR SPEED CONTROLLER ATV32  
SEE REF VAL-VAR



## COMMUNICATING CIRCUIT BREAKER CONTACTOR



ref. CONTYS

CONTYS from mecatronics is a motor starter which combines mechanical, electrotechnical and electronic technologies. It is designed to be used for directly starting up motors of up to 3kW. This compact device combines power functions (disconnecting switch, commutation) and control functions (protection). Motor settings can be displayed and programmed via a numeric screen. Supplied with **SoMove**.

### FEATURES

- protection against overloads and short-circuits.
- protection against undervoltages
- protection against isolation faults (equipment protection only)
- reset can be adjusted manually or automatically
- display of motor settings on the front or on the offset terminal:- electric current consumed per phase - adjustment of thermal circuit breaker-alarm for motor values (current, thermal status, etc.)

### FRONT FACE

- 6 terminals for three-phase power contacts
- 2 terminals for the coil's 24V AC/DC power supply
- 2 terminals for an auxiliary NO contact
- 2 terminals for an auxiliary NC contact

### ELECTRICAL FEATURES

Compatible with 1-3kW motors  
**3-phase contact**  
 - 600V max / 12A max.  
**Coil**  
 - supply voltage 24V DC/AC  
**Auxiliary contact**  
 - 400V max / 10A max.

## VARIABLE FREQUENCY AC/AC SPEED CONTROLLERS

These speed controllers for 1500W and 3000W asynchronous machines are for supplying and programming applications such as belt conveyers, blenders, extruders, pumps, fans and compressors. Putting them into service is rapid and their programming console makes them very easy to use. Software specific to each make lets you configure and monitor operation of the speed controllers. All speed controller and PLC inputs and outputs are available on the front on Ø4mm safety sockets. A potentiometer lets you adjust the sampling frequency of the speed controller, and the rotation speed of the motor. Dimensions 390 x 280 x 185mm. Supplied with operating/programming instructions, software and USB lead.

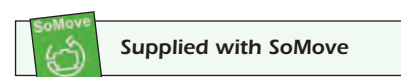

### MAIN FUNCTIONS COMMON TO THE 2 MODELS

#### Main configurable functions

- Adjustment of the deceleration/acceleration ramp
- Adjustment of the minimum/maximum speed of rotation
- Quick stop/free wheel
- Input configuration to manage the 2 rotation directions, RUN, stop type, preselected speeds, etc.
- USB lead output for PC link
- Software for speed controller setting

#### Speed controller and motor protection devices

- Output protection against short-circuits between phases
- Protection against overloads
- Protection against heating
- Protection against phase outages

#### Power terminals

- Mains input / output to motor
- Output to a braking resistance (PA/+, PB, PC/-)

#### Inputs / Outputs Signals on terminals

- 6 Input binary
- 1 Input Analogue - 10-10VDC
- 1 Input Analogue x...y mA
- 1 Safety Input STO
- 3 binary outputs
- 1 O Analogue 0-10V or 0-20mA
- 1 O Logic 30V/100mA

REF	ACVAR325	ACVAR326
Motor power	up to 1500W	up to 3000W
Power supply	200 to 240V single-phase	380 to 500V 3-phase
Frequency	50/60Hz	
Output voltage	3 x 230V	3 x 400V
Nominal output current	8A	7.1A
Bluetooth	Yes	
Braking resistance output	On terminals	
Programmation console	Yes	



ATV32

## VARIABLE FREQUENCY AC/AC AND AC/DC SPEED CONTROLLERS

### AC/AC SPEED CONTROLLERS - SIEMENS G120

These speed controllers for 1500W and 3000W asynchronous machines are for supplying and programming applications such as belt conveyers, blenders, extruders, pumps, fans and compressors. Putting them into service is rapid and their programming console makes them very easy to use. Software specific to each make lets you configure and monitor operation of the speed controllers. A potentiometer lets you adjust the sampling frequency of the speed controller, and the rotation speed of the motor. Dimensions 390 x 280 x 185mm. Supplied with operating/programming instructions, software and USB lead.

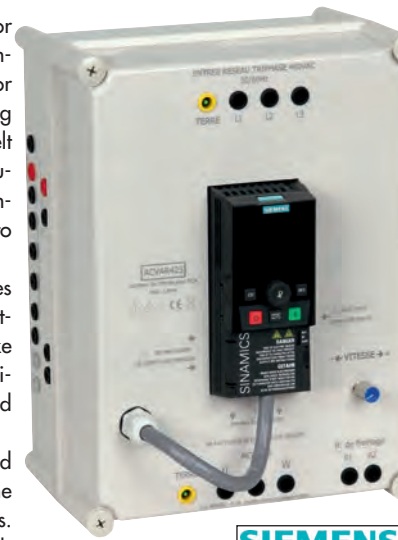

### MAIN FUNCTIONS COMMON TO THE 2 MODELS

#### Main configurable functions

- Adjustment of the deceleration/acceleration ramp
- Adjustment of the minimum/maximum speed of rotation
- Quick stop/free wheel
- Input configuration to manage the 2 rotation directions, RUN, stop type, preselected speeds, etc.
- USB lead output for PC link
- Software for speed controller setting

#### Speed controller and motor protection devices

- Output protection against short-circuits between phases
- Protection against overloads
- Protection against heating
- Protection against phase outages

#### Inputs / Outputs Signals on terminals

- 6 Input binary
- 1 Input Analogue - 10-10VDC or x...y mA
- 2 binary outputs
- 2 switchables from 0 to 10V and from 0/4 to 20mA
- 2 inverter relays 250Vac - 2A / 30Vdc - 5A

REF	ACVAR425	ACVAR426
Motor power	up to 1500W	up to 3000W
Power supply	380 to 480V 3-phase	
Frequency	50/60Hz	
Output voltage	3 x 400V	
Nominal output current	4.1A	7.3A
Braking resistance output	Yes on terminals	
Programmation console	Yes	

### AC/DC SPEED CONTROLLERS



DCVAR2 and DCVAR43 speed controllers control separately excited or permanent magnet DC motors. On the front, the RUN button powers up the speed controller and the potentiometer varies the speed of rotation of the motor. The mains and the motor connect to Ø4mm safety terminals. Supplied with operating instructions. Dim: 390 x 280mm x 185mm.

#### Speed controller protection and safety devices

- Mains side input protection by 30mA residual current circuit-breaker
- Output protection against short-circuits
- Protection against overloads
- Thermal protection against abnormal temperature rise

#### Features

- Motor power from 1500W to 3000W
- Power supply 110-115V, 220-240V or 380-415V Single-phase.
- Frequency 50/60Hz
- Armature output voltage 180V
- Nominal armature current 16A
- Field system output voltage 210V
- Field system nominal current 3A Max
- Number of quadrant in operation 1Q (Ref. DCVAR2) 4Q (Ref. DCVAR43) energy release on mains

DCVAR2	DCVAR43
Adjustments on front	
Speed: Max. and Min.	
Current limitation	
Speed stability	
Acceleration/deceleration time 1 to 15s	Acceleration/deceleration time 0 to 40s
Ri compensation	
-	Speed: Proportional gain
-	Speed: Integral gain
-	Current: Proportional gain
-	Current: Integral gain
Zero speed offset	
-	Zero speed limit

### VECTOR SPEED CONTROLLER FOR ENCODER MOTOR



ref. VCV52

Digital speed controller unit with vector flux control for asynchronous and synchronous motor with max power 2000 W (compatible with our 300 W and 1500 W motors). 8-pin connector for linking a 1024-pt encoder. A cut-out, on the unit front, gives access to the different programming keys and to a screen showing the various settings of the speed controller. A potentiometer adjusts the speed of rotation, while a switch controls motor rotation on/off. A set of security terminals gives access to the cabling of 3 programmable inputs (e.g. motor stopping in 'free wheel', reversal of the direction of rotation, preselected speed), of 2 analogue inputs 0-10 V/4-20 mA and one external braking resistor not supplied.

**Features**

- vector speed controller 2.2 kW / 3 HP max.
- Power supply 3x400 V AC 50/60 Hz + Earth
- Output 3x400 V + Earth - 5.5 A
- Speed controller output frequency adjustable from 0.1 to 599 Hz.
- Acceleration and deceleration ramp with separate adjustment.
- Vector control of current flux
- Encoder input 1024 pts
- Protection against phase loss, overcurrent, overvoltage, thermal, etc.
- Dim. 390 x 280 x 185mm

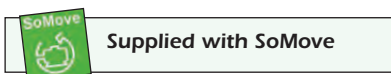

### ECONOMICAL AC/AC FREQUENCY CONVERTERS



Ref. ECOVAR-03

Variators for three-phase, squirrel-cage asynchronous machines with a power of 400 to 4000W. With their integrated control console, these variators are easy to use. Speed control by potentiometer Start/Stop button. From the control unit, the user can configure:

- the motor's rated characteristics, such as rotation speed, current, voltage, and so on
- the rotational direction
- the acceleration ramp
- the deceleration ramp
- resetting of defaults

**OPTIONS \* : CONTACT US**

- 1 brake resistance output
  - 1 fault contact output
  - 2 programmable inputs
  - 1 analog 0-10V input
  - 1 analog 4-20mA input
- \* These options require to fit these ECOVAR-15 & ECOVAR-30 variators in a plastic box



Ref. ECOVAR-15

Ref. ECOVAR-30

Reference	ECOVAR-03	ECOVAR-15	ECOVAR-30
Motor power	Up to 400W	Up to 2200W	Up to 4000W
Supply / Frequency	230V 50/60Hz on safety terminals 4mm	230V 50Hz/Single on 2P+E socket with power cable 2m	400V 3-phase on CEI 3-phase socket with power cable 2m
Output voltage	230V 3-phase on safety terminals 4mm		400V triphasé sur bornes de sécurité 4mm
Constant output current	4A	10A	8,5A
Output frequency possibility to set a maximum frequency	0 - 400Hz		
Protection against the short-circuits between phase	Secondary by fuses		
Protection against over-current	Yes		

4 years guarantee. Instructions manual is supplied with the variator.

### STUDY CASE FOR SPEED CONTROLLER ATV32 PROGRAMMABLE INPUTS / OUTPUTS



ref. VAL-VAR

**EDUCATIONAL OBJECTIVES**

- Studying a 3-phase speed controller
- Studying a setup software and setting the speed controller

**TEACHING RESOURCES STUDENT & TEACHER**

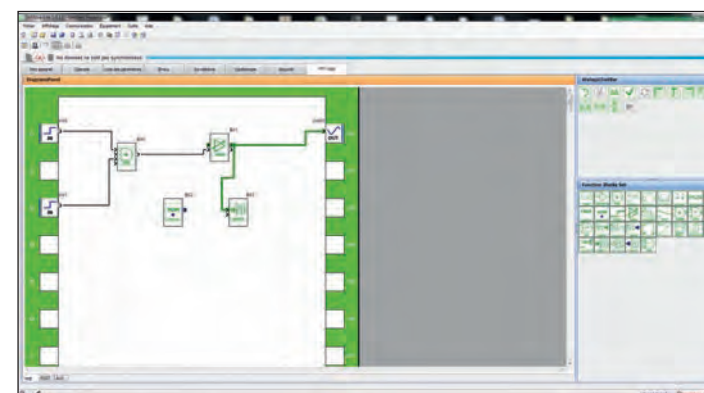

Programming screen of logical inputs/outputs of the variator.



Closed case dimensions: 530 x 430 x 200mm  
Open case dimensions: 860 x 430 x 160mm

VAL-VAR is a study case for the speed controller ATV32 for asynchronous machine. It contains all the equipment required for autonomous operation. The case connects directly to the mains 230V single-phase. The printed PVC face includes the electrical protection and control equipment, safety terminals for cabling the inputs/outputs of the speed controller and taking current measurements in each phase of the motor.

**COMPRISES**

- 1 socket + switch unit module for linking to the mains 230V-50/60Hz.
- 1 main switch.
- 1 differential magneto-thermal circuit-breaker 16A-30mA.
- 1 motor circuit-breaker type GV2
- 1 speed controller for asynchronous machine ATV32 from Schneider® power 0.18kW. This speed controller can be programmed using controls on its front or from the offset programming graphic terminal. It can also be linked to a PC using the RJ45/USB lead or Bluetooth link if your PC is so equipped. All the control inputs and outputs of the speed controller are offset to the safety terminals:
  - 6 binary inputs
  - 1 analogue input -10...10VDC
  - 1 analogue input x...y mA
  - 1 Safety Input STO
  - 3 binary outputs
  - 1 analogue output 0...10V or 0...20mA
  - 1 logic output 30V/100mA
- 1 multifunction programming graphic terminal with large screen monochrome (8 lines) 240x160 pixels. This terminal is offset using RJ45 1-m lead (supplied).
- 1 three-phase asynchronous motor 0.12kW-230/400V-AC. The rotation of its shaft can be seen through a translucent safety window.
- 1 set of jumpers, a switch and a potentiometer enable immediate operation of the speed controller.

**CASE SUPPLIED READY TO USE WITH**

- 1 set of safety leads and jumpers.
- 1 programming graphic terminal
- 1 SoMove software (Schneider Electric®) with RJ45/USB lead to link to PC
- 1 instruction manual, on CD, including the component data sheets and practical assignments for speed controller programming help.

## STAND-ALONE DC AND 3-PHASE POWER SUPPLIES



Transportable variable supplies unit (2000W or 4000W)  
 Supply from mains: 3-phase 380V/400V + neutral + earth  
 Outputs: 2 variable DC supplies 0-250V and 1 variable AC 3-phase supply 0-430V

**PROTECTION OF THE USER IN DC**

- DC supplies are isolated from mains by an insulation transformer.
- The outputs are protected against surges and short-circuits.

**OTHER SPECIFICATIONS**

- The DC power supply is delivered from a Graetz bridge (Ripple 4%)
- The DC auxiliary outputs is with a double alternation rectification of which the ripple rate changes with the load
- Emergency stop push button - key reset
- Voltage regulation by two autotransformers
- Power cable with industrial 3-phase plug supplied
- Hard-wearing LED lamps
- Outputs on safety terminals Ø 4mm.
- Dimensions 710 x 600 x 375mm - Weight COMPAK20 : 82kg - Poids COMPAK40 : 89kg.

REF	COMPAK20	COMPAK40
OUTPUT 0-250VDC	8A + voltmeter & ammeter	16A + voltmeter & ammeter
OUTPUT 0-430V 3-PHASE	5A + voltmeter & ammeter	6A + voltmeter & ammeter
AUXILIARY OUTPUT 0-250V	2.5A + voltmeter & ammeter	2.5A + voltmeter & ammeter

## HIGH POWER DC AND 3-PHASE POWER SUPPLIES



This power supply, which is varied using an autotransformer, can be networked so that it can power other stations. The DC outputs are insulated from the mains, as stipulated in the standard, and monitored by a continuous insulation monitoring device for the safety of users. This monitoring allows the DC output to be networked. The transformer complies with the NFEN6158 norm.

**INTRODUCTION AND DESCRIPTION:**

- Sheet metal cabinet, fitted on a wheeled base.
- For 3-phase 400V + Neutral + Earth supply from mains
- Voltages can be adjusted using a flywheel.
- One disconnecting switch.
- Hardwearing indicator lights
- One key-operated emergency-stop circuit breaker.
- One ammeter for the DC
- One three-position switch: DC / 0 / three-phase
- Two voltmeters: one for the DC and one for the three-phase
- Outputs: Can be connected in one of two ways – either using an internal terminal for a network cable, or safety terminals for direct use with safety leads.
- Protection: by circuit breakers
- insulation checking by a continuous insulation monitoring device
- UNIT Height: 1000mm / Width: 600mm / Depth: 350mm
- BASE Height: 100mm / Width: 810mm / Depth: 600mm

REF.	PSY40K	PSY60K	PSY90K	PSY120K	PSY150K
MAX ELECTRIC CURRENT IN DC 0-250V	16A monitored	24A monitored	36A monitored	48A monitored	60A monitored
MAX ELECTRIC CURRENT 3-PHASE 0-450V	8A	13A	13A	20A	20A
TOTAL POWER	4.000VA	6.000VA	9.000VA	12.000VA	15.000VA
FOR MAINS SUPPLY	3-PHASE 400V+N+E				

For safety the DC outputs are separated from the mains by safety isolating transformer

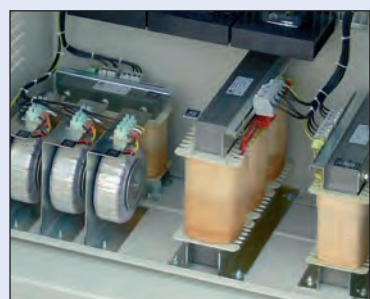

## VARIABLE POWER SUPPLIES WITH INTEGRAL SPEED CONTROLLER



Ref. AL20-ACDC

Ref. AL40-AC

Cable storage and sockets at rear.

The cabinet door open and close by key.

Power supplies on wheels with speed controller 2kW, 4kW, AC and/or DC according to the version selected.

Main start/stop and emergency stop controls on the front. Each voltage output is active from a Start/Stop switch. An indicator light signals their operation. A complete measuring unit displays the alternating values of consumption of the workstations. Other sources are not taken into account in these measurements.

**All the outputs are protected against overloads and short circuits.**

**MEASURING UNIT (on AC and ACDC models)**

Simple to use thanks to 6 keys on front, it displays the electrical values of the variable three-phase + fixed three-phase + AC speed controller outputs:

- current in each phase.
- phase-to-ground and composite voltage.
- frequency.
- active, reactive and apparent power in each of the phases and in three-phase.
- power factor in each phase and in three-phase.
- total harmonic distortion for current and voltage.
- measurement of active, reactive and apparent energy on 4 dials.

**REMOTE CONTROL OF THE MEASURING UNIT**

An RJ45 connector on the front of the cabinet enables the unit to be used remotely by means of an integral web page which displays the electrical values measured.

Dims: AL20-DC / AL20-AC / AL40-DC / AL40-AC : 500 x 500 x 980mm. Weight 90kg. Dims: AL20-ACDC / AL40-ACDC : 500 x 800 x 980mm. Weight 175kg.

Ref.	POWER 4000VA								
	VARIABLE BY AUTOTRANSFORMER				3-PHASE 3x400VAC	SPEED CONTROLLER DC 3KW	SPEED CONTROLLER AC 4KW	3 SOCKETS 230V 2P+T	MEASURING UNIT CM
	DC 0-270VDC-16A	3-PHASE 0-450VAC-8A <i>measuring by CM</i>	DC AUXILIARY 0-250VDC-2.5A	AC AUXILIARY 0-250VAC-2.5A					
AL40-DC	✓		✓	✓		✓		✓	✓
AL40-AC		✓	✓	✓	✓		✓	✓	✓
AL40-ACDC	✓	✓	✓	✓	✓	✓		✓	✓

Ref.	POWER 2000VA								
	VARIABLE BY AUTOTRANSFORMER				3-PHASE 3x400VAC	SPEED CONTROLLER DC 2KW	SPEED CONTROLLER AC 2KW	3 SOCKETS 230V 2P+T	MEASURING UNIT CM
	DC 0-270VDC-8A	3-PHASE 0-450VAC-5A <i>measuring by CM</i>	DC AUXILIARY 0-250VDC-2.5A	AC AUXILIARY 0-250VAC-2.5A					
AL20-DC	✓		✓	✓		✓		✓	✓
AL20-AC		✓	✓	✓	✓		✓	✓	✓
AL20-ACDC	✓	✓	✓	✓	✓	✓		✓	✓

**Variable DC 0-270VDC**

With isolating transformer, to standard NFC 61558. Rectification is generously oversized (ripple factor 4%). Output on 4mm terminal valid provided the autotransformer is at 0 voltage. Viewing by voltmeter and ammeter.

**Variable three-phase 0-450VAC**

The proposed voltage is 0-430V between phases (450V for 4000VA model). Output on 4mm terminal valid provided the autotransformer is at 0 voltage.

**Auxiliary 0-250VDC**

With isolating transformer, to standard NFC 61558. Viewing by voltmeter and ammeter. Double alternating rectification, the ripple factor of which varies with the charge.

**Auxiliary 0-250VDC**

Viewing by voltmeter and ammeter.

**3-phase 3x400V on 4 terminals.**

**DC speed controller**

Operation 1 quadrant, from 1.5 to 3kW, outputs for armature 180V-16A and field system 210V-3A on 4mm terminals. Adjustment of the rotation speed setting by potentiometer on the front.

**AC speed controller**

Operation 1 quadrant, 2 or 4kW outputs 3x400VAC on 4mm terminals. Adjustment of the rotation speed setting by potentiometer on the front. Configuration with SOMOVE software supplied.

### AC/DC PORTABLE POWER SUPPLY

Adjustable from 0 to 230V in DC or AC, this power supply delivers a constant current of 3A. Protected by a thermal-magnetic circuit breaker, the safety of users is ensured by the separation of circuits.

- Mains input
  - On/Off
  - DC variable output
  - AC variable output
  - Variable voltage setting
  - Max current DC or AC
  - Output displays
  - Input protection
  - Output protection
  - User's safety
  - DC output smoothing
  - AC/DC commutation
  - Connecting
  - Dimensions / Weight
- Mains cable
  - General luminous switch
  - 0-240 V
  - 0-230 V
  - rotating knob onto the unit
  - 3A
  - 1 voltmeter and 1 ammeter
  - by time delay fuse
  - thermal-magnetic circuit-breaker
  - all outputs are insulated from mains
  - by capacitors, without electronic regulation
  - CC - 0 - CA by rotary switch
  - Safety terminals 4mm
  - 210 x 245 x 350mm / 14kg

**COMPATIBLE WITH 300W MOTORS**

ref. ISOSEC1

### AC/DC POWER SUPPLY ON WHEELS (10A)

Supply of AC or DC current in 10A max.AC/DC selector switch on the front of the unit. Mains cable of 3 metres with plug.

- Mains supply
  - ON/OFF
  - Emergency stop
  - DC output
  - AC output
  - Adjustment
  - Max output current
  - Outputs display
  - Input protection
  - Outputs protection
  - Users protection
  - Filtering ACDC10
  - Filtering DC10
  - Switching
  - Dimensions / Weight
  - Wheels
- 230V, single-phase
  - push button + LED lamp
  - with key
  - 0-230V
  - 0-230V
  - by a rotary button on the top
  - 10A
  - 1 voltmeter et 1 ammeter
  - by fuse
  - by circuit breaker
  - by insulation from mains (in DC mode only)
  - no filtering. double alternation rectification with filtering. 5% of residual ripple at 10A.
  - DC - 0 - AC (by rotary switch)
  - H 510 x P 280 x P 330 mm / 49 kg
  - 4 (2 of them have a brake)



ref. DC10

Version without AC output. For solar system. Special connections (P. 147)

### DUAL DC PORTABLE POWER SUPPLY

This power supply includes :  
- one variable DC supply with voltmeter & ammeter  
- one fixed DC supply  
Protection of users is ensured by galvanic insulation of outputs.

- Mains :
  - On/Off :
  - DC variable output :
  - DC fixed output :
  - Input protection:
  - Output protection :
  - Smoothing :
  - Dimensions / weight :
- Mains cable
  - General switch and light
  - 0-240V / 3A
  - 230V / 1A
  - by time delay fuses
  - by thermal magnetic circuit-breakers
  - by capacitors
  - 210 x 245 x 350mm / 20kg.

**COMPATIBLE WITH 300W MOTORS**

ref. ISOSEC2

### DYNAMIC LOADS

#### PROPELLER FAN



Ref. VH20-400

Ref. VH20-N

On the base of a propeller fan, a 1500W motor is direct-coupled to the propeller in a 500mm diameter shaft. In this way, this small group forms a dynamic load designed for studying the load currents of a motor.

- Four wheels
- Height: 560mm
- Max. external diameter: 530mm
- Power consumption: 0.5kW
- Total weight : 27Kg
- 4 models available

- Ref. VH20 :**  
motor 230/400V - 4A/2,3A cosφ 0,33  
Supplied with type-changing interface for fast connections using HARTING® connectors.
- Ref. VH20-N :**  
motor 230/400V - 4A/2,3A cosφ 0,33 (without interface)
- Ref. VH20-400 :**  
motor 400/690V - 2,3A/1,3A cosφ 0,33  
Supplied with type-changing interface for fast connections using HARTING® connectors.
- Ref. VH20-400-N :**  
motor 400/690V - 2,3A/1,3A cosφ 0,33 (without interface)

- ref. VH20 motor 230/400V + interface
- ref. VH20-N motor 230/400V
- ref. VH20-400 motor 400/690V + interface
- ref. VH20-400-N motor 400/690V

#### INDUSTRIAL FAN MODELS



REF	SHT-40	SHT-50	SHT-60
Absorbed power	1000 W	1550 W	1650 W
Rotational speed at 50Hz	2800	2800	1400
Current by phase in A	1,8	3	3,5
Power factor	0,8	0,76	0,7
Air flow in m3/min	96	200	240
Pressure in Pa	700	1050	1100
Sound level in dB(A) at 1 meter	97	98	92
Weight in kg	28	40	78
Diameter in mm	400	500	600
Overall length	570x560x480	680x660x520	920x830x550

These fans, mounted on a wheeled chassis for easy movement, rotate around a horizontal axis so that the airflow can be pointed in any direction. These fans make up ideal three-phase loads for connection to a control requiring inductor currents to study.

- Supply: 3-phase 400V + earth
- On/Off switch on the housing of the fan
- Power cord of 5 metre without plug
- Compatible with the 3-phase 400V frequency converter

#### FAST CONNECTION OPTION FOR VH20 & VH20-400

3 metre cable with a Harting® female socket (16 points)

ref. INT-VH



MOBILE INDUCTIVE LOADS (SINGLE & 3-PHASE)



- The inductor LH\*\* can vary the power factor continuously from 0.9 to 0.1 in single-phase and 3-phase.
- PRINCIPLE**
- 3 moving laminated cores made from silicium sheets, are moved by a control wheel through 3 coils.
- The reactive power varies from 0.1kVAR to the rated power. (ie 4kVAR for LH40)
- It is possible to exceed the rated power during few minutes.
- CONNECTION**
- 4 (safety) jumps connect the coils to either 3-phase star 400V, delta 240V or single-phase 240V.
- Each phase is protected by a fuse.
- This inductor exists in 3 standard power ratings.
- Dimensions 670 x 400 x 1000mm
- Weight 70kg
- Male earth socket in standard. Female earth socket upon request.
- CEI1010 CATIII 1000Vrms pol2

REF	LH20	LH40	LH60
Reactive rated power	2KVAR	4KVAR	6KVAR
Constant current by phase	3A	6A	9A
Resistance of each coil		2.5 Ω	1.1 Ω
Weight		78kg	75kg

VARIABLE INDUCTIVE LOAD (SINGLE & 3-PHASE)

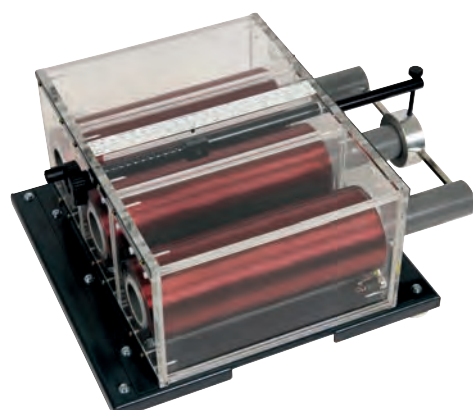

- LH10 is a bench mounted inductive load, single-phase and 3-phase.
- A screw with a handle moves the 3 laminated cores made in silicium sheets in their coils between 2 limits, the safety terminals may be connected to 3-phase star 400V, delta 240V or single-phase 240V
- PVC sealed box with safety terminals
- Dimensions 280 x 270 x 150 mm.
- Weight 21 kg.
- CEI1010 CATIII 1000Vrms pol2

Normal reactive power	1 KVAR
Reactive power for 10 min	1.5 KVAR
Constant current by phase	2A max
Variation of inductance for each phase	3 x 0.1 to 1.4H

ref. LH10

PORTABLE CAPACITIVE LOADS (SINGLE & 3-PHASE)



- The CH is a capacitive load useable from 0 to the rated power.
- 4 jump leads to plug in safety terminals, connect a bank of capacitors in 3-phase star 400V, delta 240V or single-phase 240V.
- 6 switches 5%, 10%, 15%, 20%, 25%, 25% regulate the load from 0 to the rated power without interrupting the load (ie 0 to 4kVAR for CH40).
- Safety : a discharge resistor is placed at the terminals of each capacitor.
- Male earth socket in standard. Female earth socket upon request.
- Portable unit (in steel). Dim. 500 x 300 x 200mm.
- CEI1010 CATIII 1000Vrms pol2

REF	CH05	CH20	CH40	CH60
Power	500VAR	2KVAR	4KVAR	6KVAR
Nb of switch	6			
Variation in	steps of 5%			
Type	portable			
Weight	11kg	12kg	13kg	16kg

MOBILE RESISTIVE LOADS



- The high quality of loads depends directly of the quality of switches used. All of our loads use ultra fast breaker switches, capable of breaking a DC current with an inductive load, for example the current generated by a 3kW dynamo.
- The resistive elements consist of a wire coil wound onto a ceramic core and have a good life because they are coating against the oxydation.
- The input terminals are double insulated and accept equally Ø4mm standard or safety leads.

REF	RH20	RH40	RH40S	RH60	RH80
W	2kW	4kW		6kW	8kW
Nb switches	6		7	6	
Variation in	Steps of 5%		Steps of 2.5%	Steps of 5%	
Type	with wheels				
Weight	44kg	44kg		53kg	50kg

OPERATING MODE

- The selection of the operating mode is by 4 insulated input switches DC mode or 240V single-phase. 3-phase star 400V. 3-phase delta 240V. (Exists also for voltages 127/230V in 4kW upon request)

VARIATION

- 6 switches (7 on RH40S model) with the gradation 5%, 10%, 15%, 20%, 25%, 25% allow a continual progression without a break of the load from 0 to 100% in steps of 5% (2.5% on the RH40S).
- All of the intermediate values are obtained by turning 1 or 2 switches which can be made simultaneously using 2 hands.

WHEELED UNITS

- Robust construction with furnace baked epoxy paintwork. Excess heat is vented by natural convection through a grid which prevents contact with any voltages.
- Dimensions: 660 x 400 x 880mm
- Male earth socket in standard. Female earth socket upon request.
- CEI1010 CATIII 1000Vrms pol2

MADE TO MEASURE



COMPACT RESISTIVE LOADS (SINGLE & 3-PHASE)



- Using the same switches and resistors as the other models, this load is intended for use on the laboratory bench.
- The ultra fast switches and operating mode jump leads are found on the front panel.
- DC and single-phase 240V mode/3-phase delta 240V/ 3-phase star 400V. (Exists also for voltages 127/230V in 4kW - upon request)
- Dimensions: 500 x 220 x 400mm
- Male earth socket in standard. Female earth socket upon request.
- CEI1010 CATIII 1000Vrms pol2

REF	RHP05	RHP20	RHP40
W	0,5kW	2kW	4kW
Nb switches	6		
Variation in	Steps of 5%		
Type	Portable		
Weight	15kg	18kg	17kg

## SUPERVISION UNITS FOR ELECTRIC MOTOR BENCHES







The MTD series is a complete system for monitoring a 1500W motor bench. From a PC or touch screen (according to the version), the supervisor controls and observes the operation of a bench. The electrical cabinet encloses the PLC, the speed controller and the protection devices required for the supervision and control functions. Settings and supervision software is supplied. The supervision unit is fully programmed, ready to run and open to all modifications without restriction.

### General features

- Technical cabinets with braked wheels.
- High-temperature 40 mm laminated top 750 x 670 mm.
- Console, dimensions 350 x 160 x 180 mm
- Overall dimensions: 750 x 670 x (h) 1210 mm (1460 mm touch version).
- Power supply by single-phase mains cord 230V AC.

### Software supplied with all versions

- SoMove: For settings on the speed controller.
- PLC software: For settings on the PLC.
- VijeoDesigner: For supervision. Fully programmed, ready to run. Modifiable to create your own supervision.

REF	To be combined with a 1500W motor bench (not supplied) equipped with:			To be combined with a 1500W motor bench (not supplied) equipped with:		
	MTD1	MTD2	MTD3	MTD4	MTD5	MTD6
						
Controls by	Integral 10-inch touch screen	Your PC	Your PC or Manual (on console)	Integral 10-inch touch screen	Your PC	Your PC or Manual (on console)
Supervision by		Your PC	Your PC		Your PC	Your PC
Controls and Supervision	<b>On the motor</b> Start Stop - Speed 0 to 1600 rpm - 1st and 2nd speed of rotation - Forward/Back Operation - Speed of rotation (+ and -) - Motor overload - Display of torque and speed (if brushless torque sensor) <b>On the brake:</b> From 0 to 100% - Blocking - Free wheel <b>Other:</b> Speed controller overload			<b>On the motor</b> Start Stop - Speed 0 to 1600 rpm - 1st and 2nd speed of rotation - Forward/Back Operation - Speed of rotation (+ and -) - Motor overload - Display of torque and speed (if brushless torque sensor) <b>On the alternator:</b> Voltage variation at terminals of rotary field. <b>On the resistive load:</b> load variation from 0 to 100% in 6 steps.		
Equipment of the console	Emergency stop General Start/Stop 2 RJ45 sockets Mains socket 230V Touch screen colour	Emergency stop General Start/Stop 2 RJ45 sockets Mains socket 230V	Emergency stop - General start/stop 2 RJ45 sockets Mains socket 230V Motor, Load & Speed control	Emergency stop General Start/Stop 2 RJ45 sockets Mains socket 230V Touch screen colour	Emergency stop General Start/Stop 2 RJ45 sockets Mains socket 230V	Emergency stop - General start/stop 2 RJ45 sockets Mains socket 230V Motor, Load & Speed control
Equipment of the cabinets	<ul style="list-style-type: none"> <li>• Front door, closing by 2 key locks: Control panel with indicator lights (marked PVC panel). Transparent panel: view of the speed controller and PLC information. Safety system cutting off electrical distribution if opened.</li> <li>• Rear door, closing by 2 key locks: Large PVC surface with complete wiring diagram. Safety terminals 4 mm and connection sockets for:                             <ul style="list-style-type: none"> <li>- Earths</li> <li>- Three-phase asynchronous motor 3 x 230V AC - 1500W</li> <li>- Brushless torque sensor (Din. socket)</li> <li>- Powder brake.</li> <li>- Tacho-generator 0-10/20/60V for 1000 rpm</li> </ul> </li> <li>• Main components Differential 30mA and magneto-thermal circuit-breakers. Contactor for motor control. PLC software with 24 Inputs/24 Outputs binary, Ethernet RJ45. Analogue board 4 Inputs 0-10V DC and 2 Outputs 0-10V DC Speed controller ATV32, 1500W - 3 x 230V AC.</li> </ul>			<ul style="list-style-type: none"> <li>• Front door, closing by 2 key locks: Control panel with indicator lights (marked PVC panel). Transparent panel: view of the speed controller and PLC information. Safety system cutting off electrical distribution if opened.</li> <li>• Rear door, closing by 2 key locks: Large PVC surface with complete wiring diagram. Safety terminals 4 mm and connection sockets for:                             <ul style="list-style-type: none"> <li>- Earths</li> <li>- Three-phase asynchronous motor 3 x 230V AC - 1500W</li> <li>- Brushless torque sensor (Din. socket)</li> <li>- Powder brake.</li> <li>- Tacho-generator 0-10/20/60V for 1000 rpm</li> </ul> </li> <li>• Main components Differential 30mA and magneto-thermal circuit-breakers. Contactor for motor control. PLC software with 24 Inputs / 32 Outputs binary, Ethernet RJ45. Analogue board 4 Inputs 0-10V DC and 2 Outputs 0-10V DC Speed controller ATV32, 1500W - 3 x 230V AC. Power supply controlled from the PLC. Powers the rotary field. Resistive load of 2kW can be controlled from 0 to 100% of load in 6 steps.</li> </ul>		

## SCHNEIDER® TOOLS & EQUIPMENT



Front view MTD3 Rear view MTD3

### BLOCK DIAGRAM OF MTD3 VERSION WITH 1500W MOTOR GROUP

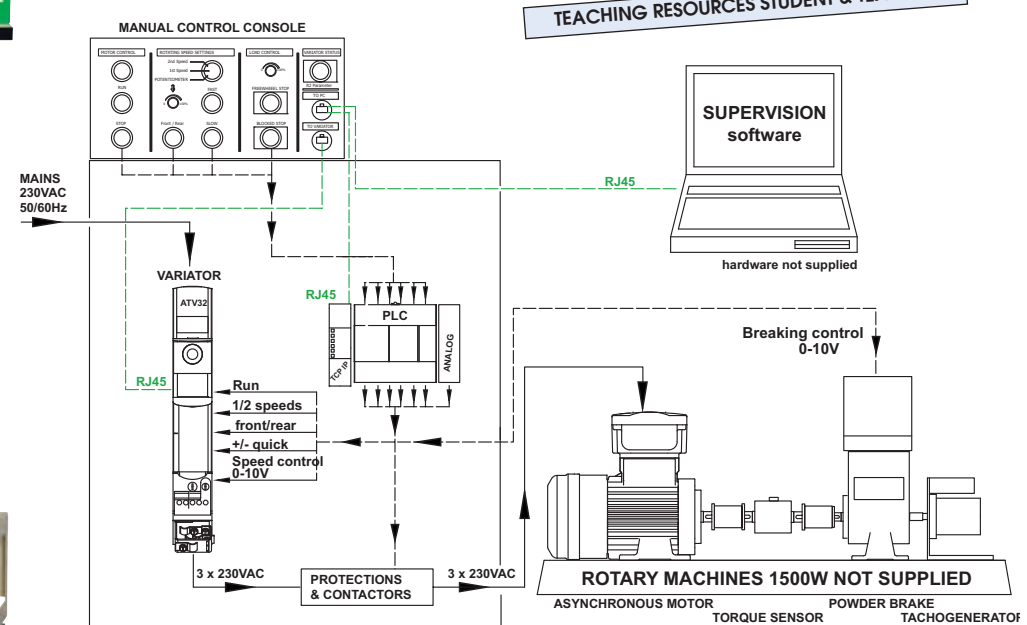

TEACHING RESOURCES STUDENT & TEACHER



SUPERVISION software hardware not supplied

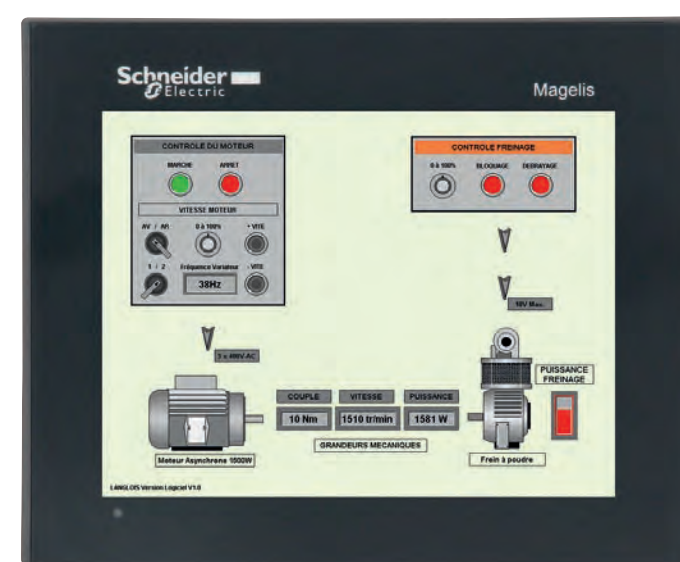

EXAMPLE OF SUPERVISION ON TOUCH SCREEN OF MTD1 MODEL (MOTOR + POWDER BRAKE)



EXAMPLE OF SUPERVISION ON PC OF MTD5 MODEL (MOTOR + THREE-PHASE ALTERNATOR)

### ACQUISITION OPTION

All the versions shown are compatible with the acquisition option.

Enables the acquisition of:

- electrical values (Voltage - Current - Absorbed power).
- mechanical values (Torque - Speed - Power).

Supplied with measuring panel and acquisition software. This option requires a bench that should be equipped with a brushless torque sensor and tacho-generator. Add -ACQUI to the end of the reference. Example: MTD4-ACQUI  
Factory assembly only.

ref. -ACQUI



## DEMO PLUG & PLAY MOTOR (AC OR DC)

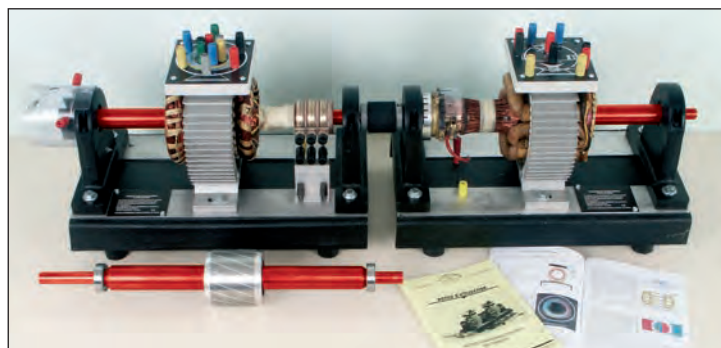

### EDUCATIONAL OBJECTIVES

- Understanding the different types of electrical motors & generators.
- Studying the operating characteristics of each device.

### TEACHING RESOURCES STUDENT & TEACHER

The various functions can be obtained by simple coupling, perfectly explained in the instructions.

Although powered by non-hazardous voltages (< 50VAC / < 100VDC), the powering up of these products is restricted to authorised staff due to the lack of protective housing.

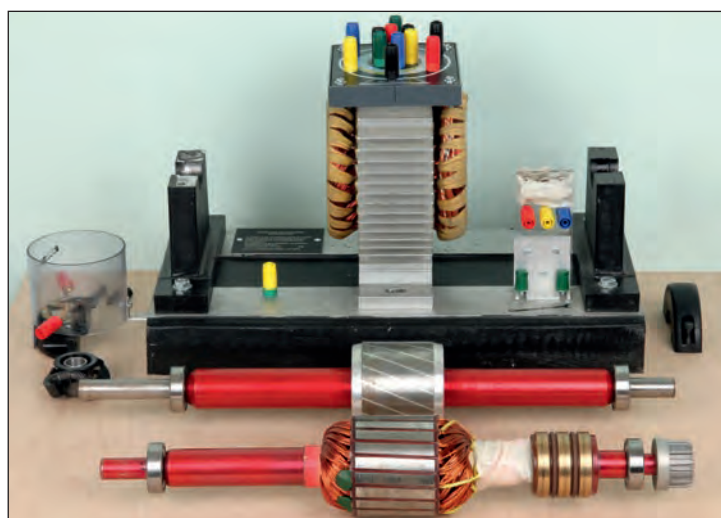

ref. DEMO-AC 48V alternating current

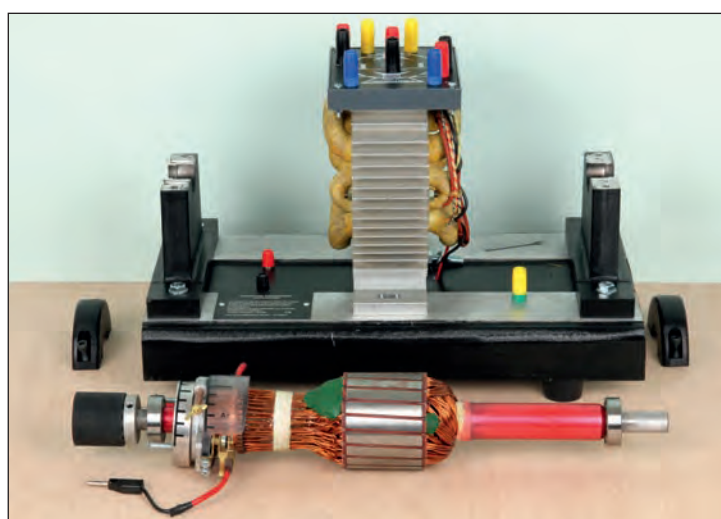

ref. DEMO-DC 48V direct current unit

### DEMO-AC: 48V ALTERNATING CURRENT

Works with the 3-phase variable 0-48V 15A power supply (not included).  
See Ref. ALI-DEMO.

Presentation: The interconnection of the windings on to a didactic terminal box provides a visual understanding of the coil of the various electrical machines and their functions. Users are able to see the position of the brushes and their movement. It is powered by 48 volt ELV. A full user manual is provided with the motor/alternator.

#### TECHNICAL DESCRIPTION

- Open frame.
- An alternating current stator.
- An aluminium base.
- Two aluminium bearings for supporting the motor shaft.
- Possibility for studying 8 different motors, with safety terminal connections
  - Single-phase motor with capacitors
  - 2-pole star connection three-phase motor
  - 4-pole delta connection three-phase motor
  - Star-delta three-phase asynchronous motor
  - Dahlander connection asynchronous squirrel cage motor
  - Three-phase slip-ring motor
  - Synchronous three-phase motor
  - Three-phase alternator
- Extension shafts.
- One squirrel cage rotor.
- One slip ring rotor. Enables the functioning of the motor and the alternator.
- One rotating brush holder.
- One brush holder mount.
- Three brushes for the slip-ring motor.
- Half coupling.
- A rotating centrifugal contact.
- A user manual.

#### DEVELOPED PRACTICAL WORK

- Single-phase alternating motor.
- Alternating motor theory.
- Repulsion-induction motor with auxiliary wiring.
- Capacitor motor.
- Capacitor start and run motor.
- Three-phase alternating motor theory.
- 2-pole star motor.
- 4-pole delta motor.
- Slip-ring motor.
- Alternator theory.
- Three-phase alternator functions.
- Synchronous motor.

### DEMO-DC: 48V DIRECT CURRENT UNIT

Works with the 3-phase variable 0-48V 15A power supply (not included).  
See Ref. ALI-DEMO.

Presentation: The interconnection of the windings on to a didactic terminal box provides a visual understanding of the coil of the various electrical machines and their functions. Series poles can be added or removed to/from the shunt poles to create a compound machine. Users are able to see the position of the brushes and their movement. It is powered by 48 volt ELV. A full user manual is provided with the motor/alternator.

#### TECHNICAL DESCRIPTION

- Open frame.
- A direct current stator.
- An aluminium base.
- Two aluminium bearings for supporting the motor shaft.
- Possibility for studying 14 different motors, with safety terminal connections
  - DC shunt motor/DC shunt motor with commutating poles
  - DC series motor/DC series motor with commutating poles

- Long shunt compound generator
- Long shunt compound generator with commutating poles
- Short shunt compound motor
- Short shunt compound motor with commutating poles.
- Separately excited shunt motor
- Universal motor without commutating poles/with commutating poles
- Repulsion motor
- Series generator with commutating poles.
- Separately excited series source rotor generator
- Separately excited series source stator generator
- Self-excited long shunt compound generator
- Self-excited short shunt compound generator
- An armature
- Half coupling.
- A user manual.

#### DEVELOPED PRACTICAL WORK

- Direct current motor theory.
- Armature reaction.
- Winding polarities.
- DC shunt motor
- DC shunt motor with commutating poles.
- Speed control.
- Long shunt compound DC motor.
- Long shunt compound DC motor with commutating poles.
- Short shunt compound DC motor.
- Short shunt compound DC motor with commutating poles.
- DC shunt motor, separately excited.
- DC generator theory.
- DC shunt generator.
- Separately excited generator.
- Series DC generator with commutating poles.
- Series-excitation generator.
- Compound generator.
- Long shunt compound DC generator.
- Short shunt compound DC motor.

## POWER SUPPLY BENCH DEMO-AC & DC

Workbench for the study of motors ref. DEMO-AC and DEMO-DC.  
Fitted with a 1200 x 750mm worktop and a 250mm width electrical cabinet.  
High mechanical and high temperature resistance stratified worktop.

#### The lateral console delivers below outputs:

- variable 3-phase + N 0-48V / 15A per phase, usable in two-phase
- variable DC 0-48V / 6A
- 12V DC / 4,2A
- 2 x 230V power sockets (2P+E)

#### Common features for all outputs:

- Hard-wearing LED lamp, without maintenance
- Emergency key release stop button, and start/stop push button
- Each output is controlled independently
- Outputs protected with circuit breakers or auto-protection with auto reset
- Outputs with voltmeter and ammeter
- Electrical drawing available on request

ref. ALI-DEMO

## DISMANTLED MOTOR



ref. MAS-DEM

MAS-DEM educational objective is theoretical research into, and discovery of, the three-phase asynchronous squirrel-cage motor. Presented in a case containing the following items:

- The motor carcass with stator wiring, fitted with a terminal block.
- The squirrel-cage rotor.
- The left and right flanges + fan.
- Screws + screwdriver kit

The 370W motor can be assembled and disassembled depending on needs. This provides a better understanding of three-phase motor technology. The instructions cover all theoretical research into the operation and technology involved in the 3-phase squirrel-cage motor

#### FEATURES OF THE CASE

- Dim. 534 x 427 x 182mm
- Weight: 10Kg



MOBILE VERSION WITHOUT TABLE  
POWER SUPPLY ON WHEELS

ref. ALI-DEMO-M



## RHEOSTATS WITH SAFETY TERMINALS 4mm

### MODELS 320W - 640W - 1300W - 1900W



#### ECO1/2

Ref.	VALUES
ECO1/2-1	0 to 1Ω / 18A
ECO1/2-3.3	0 to 3,3Ω / 10A
ECO1/2-10	0 to 10Ω / 5.7A
ECO1/2-15	0 to 15Ω / 4.5A
ECO1/2-22	0 to 22Ω / 3.8A
ECO1/2-33	0 to 33Ω / 3.1A
ECO1/2-47	0 to 47Ω / 2.6A
ECO1/2-68	0 to 68Ω / 2.2A
ECO1/2-100	0 to 100Ω / 1.8A
ECO1/2-150	0 to 150Ω / 1.5A
ECO1/2-220	0 to 220Ω / 1.2A
ECO1/2-330	0 to 330Ω / 1A
ECO1/2-470	0 to 470Ω / 0.8A
ECO1/2-680	0 to 680Ω / 0.7A
ECO1/2-1000	0 to 1000Ω / 0.6A
ECO1/2-3300	0 to 3300Ω / 0.3A

Dim. : 270 x 92 x 163mm / 1.9kg

#### ECO2

Ref.	VALUES
ECO2-0.5	0 to 0,5Ω / 50A
ECO2-1.6	0 to 1,6Ω / 28A
ECO2-5	0 to 5Ω / 16A
ECO2-11.5	0 to 11,5Ω / 10A
ECO2-16.5	0 to 16,5Ω / 8.7A
ECO2-23.4	0 to 23,4Ω / 7.2A
ECO2-33	0 to 33Ω / 6A
ECO2-50	0 to 50Ω / 5A
ECO2-106	0 to 106Ω / 3.3A
ECO2-165	0 to 165Ω / 2.8A
ECO2-325	0 to 325Ω / 1.9A
ECO2-500	0 to 500Ω / 1.6A
ECO2-1650	0 to 1650Ω / 0.9A
ECO2-5000	0 to 5kΩ / 0.5A

Dim. : 470 x 164 x 163mm / 5.5kg

#### ECO1

Ref.	VALUES
ECO1-1	0 to 1Ω / 25A
ECO1-3.3	0 to 3,3Ω / 14A
ECO1-4.7	0 to 4,7Ω / 12A
ECO1-6.8	0 to 6,8Ω / 10A
ECO1-10	0 to 10Ω / 8A
ECO1-15	0 to 15Ω / 6.5A
ECO1-25	0 to 25Ω / 5A
ECO1-33	0 to 33Ω / 4.4A
ECO1-50	0 to 50Ω / 3.6A
ECO1-68	0 to 68Ω / 3A
ECO1-100	0 to 100Ω / 2.5A
ECO1-150	0 to 150Ω / 2A
ECO1-210	0 to 210Ω / 1.7A
ECO1-330	0 to 330Ω / 1.4A
ECO1-470	0 to 470Ω / 1.2A
ECO1-650	0 to 650Ω / 1A
ECO1-1000	0 to 1000Ω / 0.8A
ECO1-1500	0 to 1500Ω / 0.65A
ECO1-2200	0 to 2200Ω / 0.54A
ECO1-3300	0 to 3300Ω / 0.44A
ECO1-4700	0 to 4700Ω / 0.37A
ECO1-6800	0 to 6800Ω / 0.31A
ECO1-10000	0 to 10kΩ / 0.25A

Dim. : 470 x 92 x 163mm / 3kg

#### ECO3

ref.	VALUES
ECO3-0.33	0 to 0,33Ω / 76A
ECO3-1.1	0 to 1,1Ω / 42A
ECO3-3.3	0 to 3,3Ω / 24A
ECO3-11	0 to 11Ω / 13A
ECO3-33	0 to 33Ω / 7.6A
ECO3-110	0 to 110Ω / 4.2A
ECO3-333	0 to 333Ω / 2.4A
ECO3-1100	0 to 1100Ω / 1.4A
ECO3-3300	0 to 3300Ω / 0.76A

Dim. : 470 x 248 x 163mm / 8.3kg

### 3-PHASE RHEOSTAT (3 RESISTANCES)



Ref	VALUES
ECOTRI-1	0 to 3 x 1Ω / 3 x 25A
ECOTRI-3.3	0 to 3 x 3,3Ω / 3 x 14A
ECOTRI-10	0 to 3 x 10Ω / 3 x 8A
ECOTRI-33	0 to 3 x 33Ω / 3 x 4.4A
ECOTRI-100	0 to 3 x 100Ω / 3 x 2.5A
ECOTRI-330	0 to 3 x 330Ω / 3 x 1.4A
ECOTRI-1000	0 to 3 x 1kΩ / 3 x 0.8A
ECOTRI-3300	0 to 3 x 3,3kΩ / 3 x 0.44A
ECOTRI-10000	0 to 3 x 10kΩ / 3 x 0.25A

Dim. : 470 x 248 x 163mm / 8.3kg

- There are 3 resistors inside this rheostat all insulated from each other
- One button allows the varying of the resistance of all of them simultaneously.
- Connected in star or delta, these rheostats act as a balanced 3-phase load.
- 9 safety terminals + 1 earth terminal.

## RHEOSTATS WITH 3 RANGES ACCORDING TO THE COUPLING

Ref.	MODE 1	MODE 2	MODE 3
SPECO-2	0 to 2Ω / 25A	0 to 1Ω / 25A	0 to 0.5Ω / 50A
SPECO-6	0 to 6.6Ω / 14A	0 to 3.3Ω / 14A	0 to 1.6Ω / 28A
SPECO-20	0 to 20Ω / 8A	0 to 10Ω / 8A	0 to 5Ω / 16A
SPECO-50	0 to 46Ω / 5A	0 to 23Ω / 5A	0 to 11.5Ω / 10A
SPECO-66	0 to 66Ω / 4.4A	0 to 33Ω / 4.4A	0 to 16.5Ω / 8.8A
SPECO-100	0 to 92Ω / 3.6A	0 to 46Ω / 3.6A	0 to 23Ω / 7.2A
SPECO-136	0 to 132Ω / 3A	0 to 66Ω / 3A	0 to 33Ω / 6A
SPECO-200	0 to 200Ω / 2.5A	0 to 100Ω / 2.5A	0 to 50Ω / 5A
SPECO-420	0 to 420Ω / 1.7A	0 to 210Ω / 1.7A	0 to 105Ω / 3.4A
SPECO-660	0 to 660Ω / 1.4A	0 to 330Ω / 1.4A	0 to 165Ω / 2.8A
SPECO-1,3K	0 to 1.3kΩ / 1A	0 to 650Ω / 1A	0 to 325Ω / 2A
SPECO-2K	0 to 2kΩ / 0.8A	0 to 1kΩ / 0.8A	0 to 500Ω / 1.6A
SPECO-6K	0 to 6.6kΩ / 0.44A	0 to 3.3kΩ / 0.44A	0 to 1.6kΩ / 0.9A
SPECO-20K	0 to 20kΩ / 0.25A	0 to 10kΩ / 0.25A	0 to 5kΩ / 0.5A

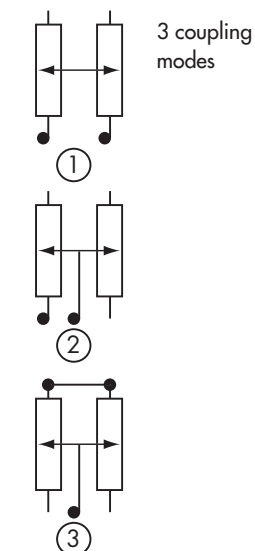

## STANDARD TRANSFORMERS

From 63 to 160VA transformers are moulded. For higher power, transformers are covered (steel protective cover).  
Summary table of the single-phase transformers the most frequently sold.



Ref.	Type	Power	Primary 230V	Secondary
MN00-10	single-phase steel-covered	40VA	■	230V ■
MN00-11	single-phase steel-covered	40VA	■	230V ■
MN00-15	single-phase moulded	40VA	■	12V ■
MN01-02	single-phase moulded	63VA	■	24V ■
MN01-11	single-phase steel-covered	63VA	■	230V ■
MN01-13	single-phase moulded	63VA	■	2 x 12V ■
MN02-02	single-phase moulded	100VA	■	24V ■
MN02-03	single-phase moulded	100VA	■	2 x 12V ■
MN02-13	single-phase moulded	100VA	■	2 x 12V ■
MN03-01	single-phase steel-covered	160VA	■	230V ■
MN03-02	single-phase moulded	160VA	■	24V ■
MN03-11	single-phase steel-covered	160VA	■	230V ■
MN03-12	single-phase moulded	160VA	■	24V ■
MN03-13	single-phase moulded	160VA	■	2 x 12V ■
MN05-02	single-phase steel-covered	250VA	■	24V ■
MN08-00	single-phase steel-covered	500VA	■	230V ■

PRIMARY 230V ON SAFETY TERMINALS



PRIMARY 230V ON MAINS CABLE

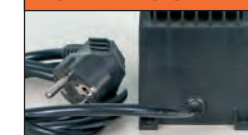

SECONDARY ON 3 SAFETY TERMINALS



SECONDARY ON 2 SAFETY TERMINALS



SECONDARY ON 2P SOCKET



SINGLE-PHASE TRANSFORMERS



Insulation transformers which conform to standard NFEN61558 with protective cover (contact us regarding bare models).

- Tolerance 10%
- Value at 100Hz (or 50Hz in fullwave)

**CONNECTION METHOD**  
To be specified when ordering

- Primary :  $\varnothing$ 4mm safety terminals or mains cable 2P+E (please select).
- Secondary :  $\varnothing$ 4mm safety terminals or fitted power socket (2 pins)

The transformers of this table are with one winding at the primary and one winding at the secondary, without intermediate taps. In other cases, please contact us.

Ref.	Power VA	Type
MN00	40	Moulded
MN01	63	Moulded
MN02	100	Moulded
MN03	160	Moulded
MN04	200	Covered
MN05	250	Covered
MN06	300	Covered
MN07	400	Covered
MN08	500	Covered
MN09	630	Covered
MN10	750	Covered
MN11	1000	Covered
MN12	1600	Covered
MN13	2500	Covered
MN14	3000	Covered
MN15	4000	Covered

**SAMPLE OF ORDER**  
LABORATORY SINGLE-PHASE TRANSFORMER

POWER \_\_\_\_\_ 750VA (see selection table opposite)  
REF. \_\_\_\_\_ MN10 (see selection table opposite)

**PRIMARY** \_\_\_\_\_ 230V (SELECT)  
**CONNECTION METHOD** \_\_\_\_\_  
 MAINS CABLE  
 SAFETY TERMINALS

**SECONDARY** \_\_\_\_\_ 24V (SELECT)  
**CONNECTION METHOD** \_\_\_\_\_  
 SAFETY TERMINALS  
 POWER SOCKET (2P)

COVERED SINGLE-PHASE INDUCTION COILS (SAFETY TERMINALS)

	1mH	3mH	10mH	30mH	100mH	300mH	1H	3H
0,1A	/	/	/	/	/	/	L101	L301
0,5A	/	/	/	L30M05 (4,70 $\Omega$ )	L100M05 (11 $\Omega$ )	L300M05 (10,3 $\Omega$ )	L105 (23 $\Omega$ )	L305 (30,8 $\Omega$ )
1A	L1M1 (0,25 $\Omega$ )	/	L10M1 (0,6 $\Omega$ )	L30M1 (1,74 $\Omega$ )	L100M1 (2,27 $\Omega$ )	L300M1 (2,80 $\Omega$ )	L11 (8 $\Omega$ )	L31 (18,00 $\Omega$ )
2A	/	/	L10M2 (0,5 $\Omega$ )	L30M2 (0,80 $\Omega$ )	L100M2 (1,40 $\Omega$ )	L300M2 (4,00 $\Omega$ )	L12 (4,70 $\Omega$ )	L32 (8,30 $\Omega$ )
3A	/	L3M3 (0,24 $\Omega$ )	L10M3 (0,34 $\Omega$ )	L30M3 (0,66 $\Omega$ )	L100M3 (1,00 $\Omega$ )	L300M3 (0,90 $\Omega$ )	L13 (4,30 $\Omega$ )	L33 (6,40 $\Omega$ )
4A	L1M4 (0,16 $\Omega$ )	L3M4 (0,20 $\Omega$ )	L10M4 (0,29 $\Omega$ )	L30M4 (0,44 $\Omega$ )	L100M4 (0,85 $\Omega$ )	L300M4 (4,10 $\Omega$ )	L14 (2,00 $\Omega$ )	/
5A	L1M5 (0,09 $\Omega$ )	L3M5 (0,13 $\Omega$ )	L10M5 (0,19 $\Omega$ )	L30M5 (0,20 $\Omega$ )	L100M5 (0,52 $\Omega$ )	L300M5 (1,70 $\Omega$ )	L15 (2,30 $\Omega$ )	/
6A	L1M6 (0,09 $\Omega$ )	L3M6 (0,13 $\Omega$ )	L10M6 (0,19 $\Omega$ )	L30M6 (0,40 $\Omega$ )	L100M6 (0,60 $\Omega$ )	L300M6 (0,90 $\Omega$ )	L16 (1,60 $\Omega$ )	/
8A	L1M8 (0,04 $\Omega$ )	L3M8 (0,07 $\Omega$ )	L10M8 (0,12 $\Omega$ )	L30M8 (0,15 $\Omega$ )	L100M8 (0,30 $\Omega$ )	L300M8 (5(0,66 $\Omega$ ))	/	/
10A	L1M10 (0,04 $\Omega$ )	L3M10 (0,066 $\Omega$ )	L10M10 (0,15 $\Omega$ )	L30M10 (0,16 $\Omega$ )	L100M10 (0,40 $\Omega$ )	L300M10 (0,51 $\Omega$ )	/	/
15A	L1M15 (0,021 $\Omega$ )	L3M15 (0,041 $\Omega$ )	L10M15 (0,07 $\Omega$ )	L30M15 (0,13 $\Omega$ )	L100M15 (0,30 $\Omega$ )	L300M15	/	/
20A	L1M20 (0,019 $\Omega$ )	L3M20 (0,03 $\Omega$ )	L10M20 (0,06 $\Omega$ )	L30M20 (0,09 $\Omega$ )	L100M20	L300M20	/	/



3-PHASE TRANSFORMERS



Insulated transformers which conform to standard NFEN61558, with protective cover.  
Contact us regarding bare model

The transformers of this table are with 3 windings at the primary and 3 windings at the secondary, without intermediate taps. In other cases, please contact us.

REF	Power VA
TR05	250
TR08	500
TR09	630
TR10	750
TR11	1000
TR12	1600
TR13	2500
TR14	3000
TR15	4000

**SAMPLE OF ORDER**  
LABORATORY 3-PHASE TRANSFORMER

POWER \_\_\_\_\_ 1000VA (see selection table above)  
REF. \_\_\_\_\_ TR11 (see selection table above)

**PRIMARY** (choice of couplings and voltage)  
 STAR TYPE  
 SEPARATE TYPE  
 DELTA TYPE

**SECONDARY** (choice of couplings and voltage)  
 STAR TYPE  
 SEPARATE TYPE  
 DELTA TYPE

ZIG-ZAG TRANSFORMERS



REF	POWER	Primary	All couplings Secondary
ZIG11	1000VA	230/400 V	6x115V or 6x133V
ZIG12	1600VA	230/400 V	6x115V or 6x133V
ZIG13	2500VA	230/400 V	6x115V or 6x133V
ZIG14	3000VA	230/400 V	6x115V or 6x133V
ZIG15	4000VA	230/400 V	6x115V or 6x133V

**PRINCIPLE**  
Our primary zig-zag transformer comprises three windings, whereas the secondary one comprises six half-windings. All of these windings are galvanically isolated from each other. Students practise wiring the primary winding into a star or delta, and the secondary winding into a star, delta or zig-zag. In total, this is six schematics: Yy, Yd, Yz, Dy, Dd, Dz.

The coils are designed in such a way that the voltage outputs always correspond to the 230/400V standard. The section of the wire is calculated in such a way that the rated power in the secondary is available regardless of the connection schematic used.

Interconnections are made using safety cables, directly on the terminal board. The following are symbolised on the terminal board:

- the coils
- with a point, the direction of the coil
- with upper case letter, the terminals of the primary transformer
- with lower case letters, the terminals of the secondary transformer.
- the safety conductor

Comprehensive instructions with Fresnel diagrams explain how the combination of coils alters the phase-to-ground and composite voltages. They explain how to determine the time index.

A method shows how to find out the direction of the coils in an unmarked zig-zag transformer.

### STUDY OF THE 1500VA THREE-PHASE TRANSFORMER

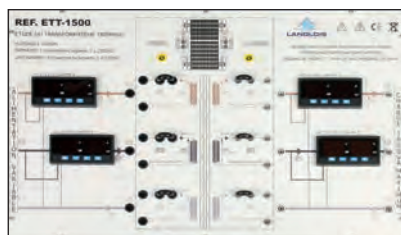

Upper face  
4 multi-displays show the active powers, voltages, currents and power factors at the primary and at the secondary.  
Engraved synoptic equipped with safety sockets to facilitate the wiring.



ref. ETT-1500

#### EDUCATIONAL OBJECTIVES

- Study of a 3-phase transformer with no load, in short-circuit and loaded
- Creation of Star / Delta wiring according to the primary/secondary voltages selected
- Electrical measurements of the different values
- Calculation of the powers with the method of the 2 wattmeters

#### TEACHING RESOURCES & PRACTICAL WORK

#### Proposed practical work

- Understanding of the characteristics given on the identification plate
- Readings of the characteristics with no load, in short-circuit and loaded
- Study and influence of the different primary and secondary couplings
- Calculation of the transformation ratio
- Study of the clock hour figure
- Power statement with the method of the 2 wattmeters
- Study of the equivalent diagram for one phase

#### COMPOSITION OF THE MOBILE CABINET ON WHEELS

- Emergency stop, main switch, 'On' indicator light
- Primary and secondary electrical protection
- Variable three-phase autotransformer
- 1500VA three-phase transformer
- Primary 3 x 230V / Secondary 3 x 230V separate windings
- 4 digital multi-displays (2 at primary and 2 at secondary) showing the active power, voltage, current and cosφ
- 4mm safety terminals including 3 at secondary for connecting a load
- HYPRA plug with 3-m lead for linking to the three-phase network
- Dimensions: 710 x 600 x 375mm - Weight: 72 kg
- Supply voltage: 3 x 400V-AC 50Hz + N +E

An autotransformer enables the voltage at the primary to be varied. Separate windings allow for practical work with no load, in short-circuit, and loaded with different Star or Delta couplings.

### TRAINING MODEL OF SINGLE-PHASE TRANSFORMER 140VA



ref. ETM140

ETM140 allows the study of a single phase transformer. It is made up with a portable console which includes:

- 1 X 140VA single phase transformer
  - Primary: 230V power supply. Use: 240V protected by fuses and output on safety terminals.
  - Secondary: 1 x 15V/3.6A winding, 2 x 12V/3.6V independent windings, fuses protected and output on safety terminals.
  - 3 displays on the primary (Current - Voltage - Power) show the absorbed electric values.
  - 6 displays on the secondary (2 x Current - 2 x Voltage - 2 x Power) show electric values of secondary outputs.
  - 1 variable single phase autotransformer, 0-240V 2.5A output, fuses protected, with safety terminals, can supply the transformer primary.
  - 1 set of Ø4mm safety test leads.
- User's manual includes: A theoretical study about single phase transformer and practical works with the 140VA transformer.

#### Specifications:

- Dimensions: 1000x160x180mm + handle
- Weight: 18kg
- Supply: 230V mains cable

#### EDUCATIONAL OBJECTIVES

- Theoretical practical study of a single-phase transformer with no load and loaded.
- Studying the electromagnetic induction

User's manual with theoretical study

AVAILABLE MODULAR SOLUTION



### VARIABLE TRANSFORMER (INSULATED)

- The case contains one insulation transformer and one variable autotransformer.
- The primary is powered by the mains supply (230V)
- The secondary can be connected by secure terminals of Ø4mm.
- 2 powers available.
- Dimensions : 210 x 245 x 350mm.

REF	SEC1	SEC2	SEC3	SEC4
Output voltage	0-240V		0-48V	
Current	2.5A	5A	12.5A	25A
Weight	19kg	25kg	27kg	26kg

#### TRANSFORMERS ISOLATED FROM THE MAINS



### SAFETY DISMANTLED TRANSFORMER

#### MAGNETIC CIRCUIT

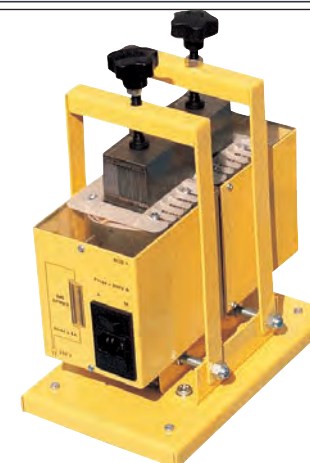

ref. MAG800

User safety is maintained by SAFETY TERMINALS and a double insulation unit.

- Stacking of silicon sheet in U-shape.
- H: 200mm.
- L: 120mm.
- 40 x 40mm section
- The magnetic circuit is fixed onto a 230 x 150mm base with rubber feet.
- Two quick gripping clamps hold the head, closing the magnetic circuit.

#### SECONDARY COIL

- consists of 2 windings in series, each one with 220 turns, 3.6A.
- When empty, this coil delivers 230V, with a mid-point of 110V.
- Outputs to safety terminals.
- Double insulation
- Dimensions: 115 x 115 x 95mm

ref. BOB4

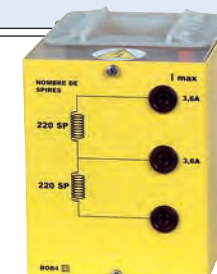

#### PRIMARY COIL

- 230V power supply.
- 800VA power
- 440 turns max. I = 4A
- Supplied with a power lead, an On/Off button, a safety fuse
- Dimensions. : 115 x 115 x 95mm

ref. BOB1



#### PRIMARY COIL

- 230V power supply.
- 800VA power
- 440 turns max. I = 4A
- Connexion on safety terminals
- Dimensions. : 115 x 115 x 95mm

ref. BOB6



#### SECONDARY COIL

- Consists of 5 windings in series.
- Outputs to safety terminals.
- Double insulation
- Dimensions: 115 x 115 x 95mm

Nb of turns	6	12	24	48	96
Current in A	50	25	13	6,6	3,3

ref. BOB2

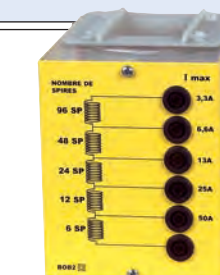

#### SECONDARY COIL

- Consists of 2 windings in series, each with 1000 turns, 0.8A.
- Warning - when empty, this coil delivers 1000V.
- Outputs to safety terminals.
- Double insulation
- Dimensions. : 115 x 115 x 95mm

ref. BOB3

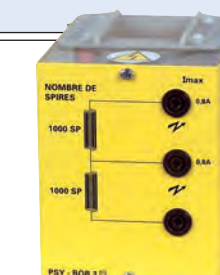

## VARIABLE AUTOTRANSFORMERS

These variable autotransformers are available in 3 designs.

- Bare for references finishing with a "N"
  - With a stainless steel case for references finishing with "A" or "P"
  - Protected by a case, fitted with 4 casters, circuit breaker and ON/OFF LED for references finishing with a "PE"
- Covered (P and PE) units have a mains cable at the primary and safety terminals at the secondary.



MADE TO MEASURE

### BARE DESIGN



TRT8N

#### Single-phase

Ref	Power	Primary	Secondary	Secondary	Weight	Dims mm
ALT5N	1.25kVA	220/240V	0-250V	5A	5,2kg	151 x 151 x 123mm
ALT7N	1.85kVA	220/240V	0-260V	7A	7,7kg	175 x 175 x 123mm
ALT13N	3.38kVA	220/240V	0-260V	13A	13,3kg	233 x 233 x 123mm
VAR92N	5.20kVA	220/240V	0-260V	20A	19kg	294 x 294 x 145mm

#### Three-phase

Ref	Power	Primary	Secondary	Secondary	Weight	Dims mm
TRT5N	3.72kVA	380/400V	0-430V	5A	19kg	155 x 155 x 407mm
TRT8N	6.23kVA	380/400V	0-450V	8A	27kg	181 x 181 x 407mm
TRT13N	10.13kVA	380/400V	0-450V	13A	39kg	233 x 233 x 422mm
3VAR92N	15.60kVA	380/400V	0-450V	20A	56kg	310 x 310 x 402mm

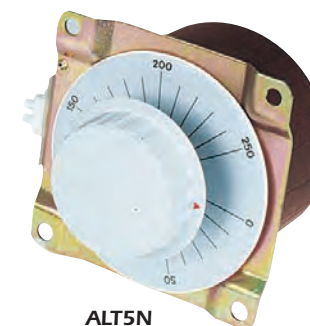

ALT5N

### COVER DESIGN - PRIMARY ON MAINS CABLE



TRT30A

#### Single-phase

Ref	Power	Primary	Secondary	Secondary	Weight	Dims mm
ALT5A*	1.25kVA	220/240V	0-250V	5A	6.2kg	Ø170 x 157mm
ALT7A*	1.85kVA	220/240V	0-260V	7A	8.8kg	Ø202 x 157mm
ALT13A*	3.28kVA	220/240V	0-260V	13A	13.5kg	Ø268 x 157mm
ALT15A	3.90kVA	220/240V	0-260V	15A	22kg	286 x 286 x 200mm
VAR92P	5.20kVA	220/240V	0-260V	20A	25,5kg	350 x 320 x 550mm

\* fuses at secondary

#### Three-phase

Ref	Power	Primary	Secondary	Secondary	Weight	Dims mm
TRT8A	6.23kVA	380/400V	0-450V	8A	33kg	200 x 200 x 468mm
TRT13A	10.13kVA	380/400V	0-450V	13A	48kg	286 x 286 x 468mm
TRT30A	23.38kVA	380/400V	0-450V	30A	92kg	450 x 450 x 700mm

ALT5A



ALT15A

### COVER DESIGN WITH CIRCUIT BREAKERS & LIGHT - PRIMARY ON MAINS CABLE



TRT8-PE

#### Single-phase

Ref	Power	Primary	Secondary	Secondary	Weight	Dims mm
ALT5-PE	1.25kVA	220/240V	0-250V	5A	8.9kg	230 x 140 x 250mm
ALT7-PE	1.85kVA	220/240V	0-260V	7A	11.5kg	230 x 140 x 250mm
ALT13-PE	3.28kVA	220/240V	0-260V	13A	14.6kg	230 x 140 x 250mm

#### Three-phase

Ref	Power	Primary	Secondary	Secondary	Weight	Dims mm
TRT5-PE	3.72kVA	380/400V	0-430V	5A	30kg	280 x 340 x 510mm
TRT8-PE	6.23kVA	380/400V	0-450V	8A	37kg	280 x 340 x 510mm
TRT13-PE	10.13kVA	380/400V	0-450V	13A	48kg	280 x 340 x 530mm
3VAR92P	15.60kVA	380/400V	0-450V	20A	71kg	350 x 360 x 600mm

Models on wheels



ALT5-PE

## SAFETY VARIABLE INDUCTANCE (INSULATED CASE)

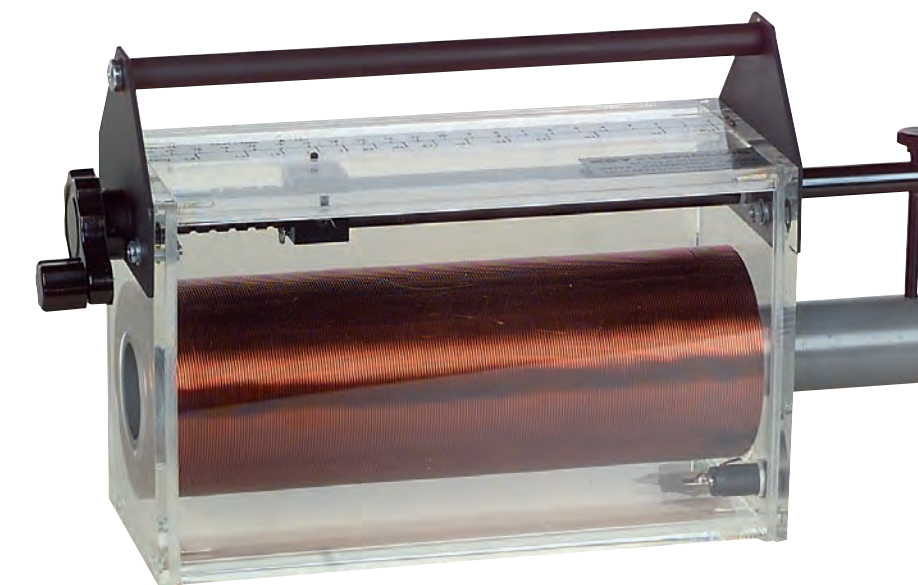

ref. PSYJR

### CEI1010 CATIII 1000Veff pol2

Inductor equipped with safety terminals. The whole unit is double insulated. The inductance coil is fitted in a transparent case.

**The handle and moving parts are metal.**

- Inductance: progressively adjustable from 0.15 to 1.4H.
- Resistance: 12Ω
- Max. current: 2A
- Max voltage : 250V
- Overvoltage factor: 22
- Core made with a stacking of silicon sheets
- Graduated in Henry and in centimetres.
- Dimensions: 280 x 150 x 90mm
- Weight: 7kg



---

[www.langlois-france.com](http://www.langlois-france.com)

---

info@langlois-france.com - Tél. : 0033 556 75 13 33

Z.I. du haut-vigneau 33174 Gradignan cedex