



MODULAR
SOLUTIONS

2023



STUDY OF WIRINGS FOR STARTING ASYNCHRONOUS MOTORS

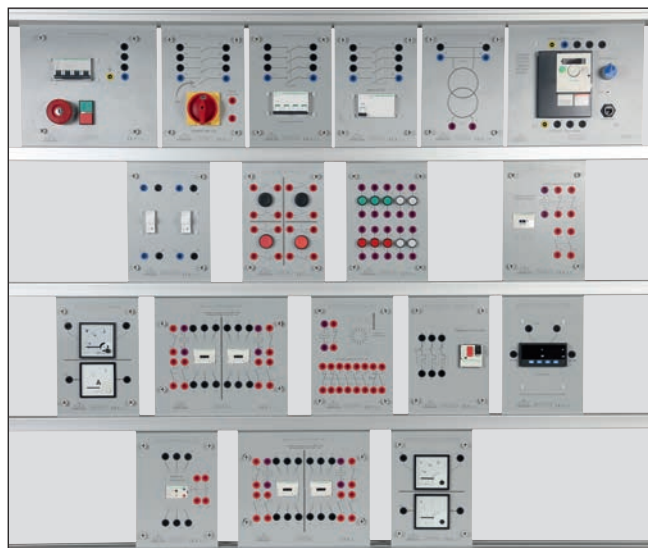

Sockets on the back of the console for connecting the modules

Set of modules for studying the different types of wiring for starting asynchronous motors.
The modules are cabled using safety leads Ø4mm.
Compatible with asynchronous motors 400/690V 1500W max.

ref. QUICK-CPLUS

ref. QUICK-C without frame and console

TEACHING RESSOURCES STUDENT & TEACHER

FAN OPTION

QUICK-C can be completed by a fan.

- 300W 400/690V three-phase fan
- Rated speed 1500 rpm
- Power supply through 4mm dual chamber safety terminals

ref. KT-1M

Protection grid removed for photo purposes only

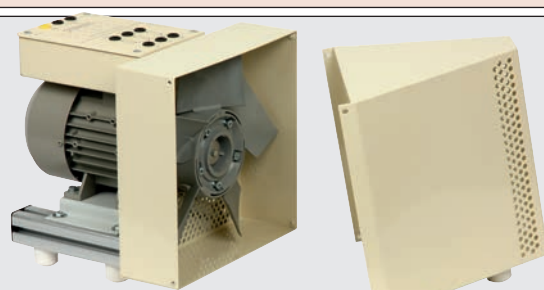

EDUCATIONAL OBJECTIVES

- Study of wiring diagrams for starting asynchronous motors.
- Study and operation of direct start-up.
- Study and operation of direct start-up with reversal of the direction of rotation.
- Study and operation of star/delta start-up.
- Configuration of a speed controller with software.
- Study and operation of start-up with speed controller.
- Using a digital wattmeter, ammeter and voltmeter.

Proposed Practical Works

- Creation of the wiring diagrams of different types of motor start-up.
- Creation of the different wirings of motor start-ups such as direct, direct with reversal of the direction of rotation, star/delta, with speed controller.
- Configuration of the speed controller using the SOMOVE software from Schneider
- Reading of the currents and voltages at the terminals of the asynchronous motor.
- Calculation of the absorbed power.

Comprises

- 1 Module – Distribution of three-phase voltage + Neutral 400V-50Hz
- 1 Module – 2 two-pole cut-out devices
- 1 Module – Four-pole thermal-magnetic circuit-breaker 4A D-curve
- 1 Module – Residual current four-pole switch 30mA
- 1 Module – Three-pole thermal magnetic circuit-breaker, motor support
- 1 Module – Four-pole isolating switch
- 1 Module – Transformer 230V/24VAC-50Hz 120VA
- 1 Module – Four pushbuttons
- 1 Module – 10 indicator lights 24VAC-50Hz
- 1 Module – Reversing contactor 24VAC-50Hz with 2NO+2NC
- 1 Module – Contactor 24VAC-50Hz with 2NO+2NC
- 1 Module – Contactor 24VAC-50Hz with 2NO+2NC
- 1 Module – Timed contactor 24VAC-50Hz
- 1 Module – Thermal relay
- 2 Modules – Analogue voltmeter (400V) and ammeter (10A) displays.
- 2 Modules – Digital wattmeter displays.
- 1 Module – Speed controller 1.5kW power supply and 3-phase 400V output.
- 1 set of safety leads for carrying out the different practical works.
- 1 frame with wheels (H x W x D): 1610 x 940 x 500mm equipped with rack for cords (30 fingers)
- 1 single-phase power console:
 - 1 thermal magnetic circuit breaker (16A)
 - 1 Emergency stop push button with key
 - 1 Push button + LED indicator
 - 1 230V single-phase output on 4mm safety terminals
 - 2 230Vac sockets (2P + E) + 12 230Vac sockets (2P + E), at the back

STUDY OF AN ASYNCHRONOUS MOTOR 1500W WITH POWDER BRAKE



The set can be supplied without the motor set, please ask for details.

Comprises

- 1 Power supply module with RC circuit-breaker and emergency stop button.
- 1 Speed controller module 1500W (single-phase or 3-phase according to version) with SoMove programming software.
- 1 Module with thermal-magnetic circuit-breaker for motor support.
- 1 Wattmeter switch module.
- 1 Power supply module 0-20V DC for powder brake supply.
- 1 Voltage digital display module.
- 1 Current digital display module.
- 1 Motor torque digital display module.
- 1 Rotation speed digital display module.
- 1 Analogue wattmeter RMS AC+DC.
- 1 Complete motor set on wheeled cart equipped with three-phase asynchronous motor 230/400V - 1500W, powder brake, rotary torque sensor, and tachometer generator.
- 1 set of safety leads for carrying out the different practical works.
- 1 frame with wheels (H x W x D): 1610 x 940 x 500mm equipped with rack for cords (30 fingers)

Single-phase version

- 1 single-phase power console:
 - 1 thermal magnetic circuit breaker (16A)
 - 1 Emergency stop push button with key
 - 1 Push button + LED indicator
 - 1 230V single-phase output on 4mm safety terminals
 - 2 230Vac sockets (2P + E) + 12 230Vac sockets (2P + E), at the back

3-phase Version

- 1 three-phase power console:
 - 1 4-poles thermal magnetic circuit breaker (16A)
 - 1 Emergency stop push button with key
 - 1 Push button + LED indicator
 - 1 3-phase output 3x 400V+N+E on 4mm safety terminals
 - 2 230Vac sockets (2P + E)
 - 12 230Vac sockets (2P + E) with ON indicator (back side)

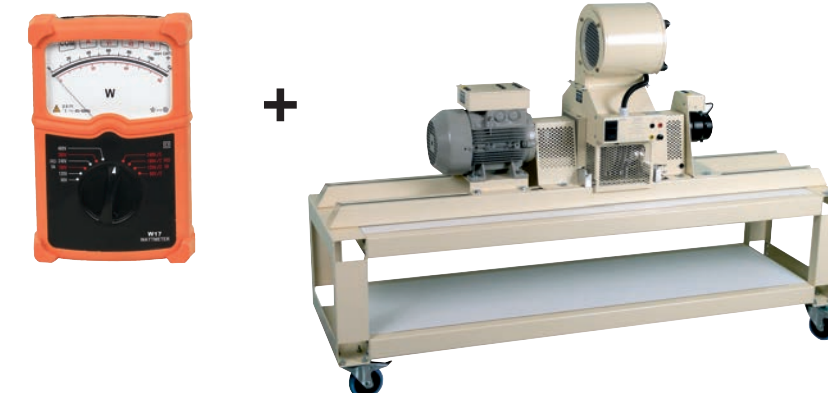

Sets of modules (H-250mm) and rotating machinery for studying an asynchronous motor 1500W coupled with a powder brake with torque sensor and tachometer generator.

ref. QUICK-FPLUS (single-phase)
Requires connection to a mains single-phase electricity supply 230V AC

ref. QUICK-F without frame and console

ref. QUICK-FTPLUS (3-phase)
Requires connection to a mains 3-phase electricity supply 3 x 400V AC + Neutral

ref. QUICK-FT without frame and console

TEACHING RESSOURCES STUDENT & TEACHER

EDUCATIONAL OBJECTIVES

- Study the wiring diagram between a speed controller and an asynchronous motor.
- Study the configuration of a speed controller using SoMove software.
- Study the no-load behaviour of a three-phase asynchronous motor 1500W.
- Study the with-load behaviour of a three-phase asynchronous motor 1500W.
- Read and plot the electrical and mechanical characteristics of an asynchronous motor.

Proposed Practical Works

- Creation of the wiring diagram of a speed controller and an asynchronous motor.
- Creation of the configuration of a speed controller using SoMove software.
- Creation of the no-load and with-load tests of the asynchronous motor.
- Calculations & plots of the electrical and mechanical characteristics of the motor bench.



Sockets on the back of the console for connecting the modules

STUDY OF THE SYNCHRONIZATION OF AN ALTERNATOR WITH THE ELECTRICAL GRID



The set can be supplied without the motor set, please ask for details.



Sockets on the back of the console for connecting the modules

Set of modules (H-250mm) and rotating machinery for studying the synchronization of an alternator 1500W with the electricity grid 3 x 400V.

EDUCATIONAL OBJECTIVES

- Understand the operation of a synchronous alternator.
- Understand the rules of synchronization with the electricity grid.
- Use a synchronoscope.
- Study the wiring diagram between a speed controller and an asynchronous motor.
- Creation of the configuration of a speed controller with software.
- Study the no-load and with-load behaviour of a 3-phase asynchronous motor 1500W.
- Study the no-load and with-load behaviour of an alternator.
- Read and plot the electrical and mechanical characteristics of the motor bench.

ref. QUICK-JPLUS

ref. QUICK-J without frame and console

TEACHING RESSOURCES STUDENT & TEACHER

Proposed Practical Works

- Creation of the wiring diagram of a speed controller and the asynchronous motor.
- Configuration of the speed controller with software.
- Creation of the wiring of the alternator and the synchronoscope.
- Creation of the no-load and with-load tests of the asynchronous motor.
- Creation of the no-load and with-load tests of the alternator.
- Calculations and plots of the electrical and mechanical characteristics of the motor bench.

Comprises

- 1 Single-phase power supply module with RC circuit-breaker and emergency stop button.
 - 1 Single-phase speed controller module 230V AC – 3x230V AC, 1500W. Adjustment of the rotation speed setting by potentiometer on the front.
 - 1 Wattmeter switch module.
 - 5 digital display modules:
Voltage - Current - Power - Motor torque - Rotation speed.
 - 1 Indicator module of phase order on the alternator side.
 - 1 Indicator module of phase order on the electricity grid side.
 - 1 Switching module with display of the matching of the voltages, speed of synchronism, frequency of the alternator, and output voltage of the alternator.
 - 1 Machinery set on wheeled cart comprised of:
 - 1 Asynchronous motor 1500W - 3x 230V/3x400V
 - 1 Brushless rotary dynamic torque sensor
 - 1 Synchronous machine 1500W - 3x230V/3x400V
 - 1 Tachometer generator 10V/1000 revs
 - 1 Analogue wattmeter RMS AC+DC.
 - 1 Variable power supply 0-240V AC/DC for supplying the polar wheel of the alternator.
 - 1 set of safety leads for carrying out the different practical works.
 - 1 frame with wheels (H x W x D): 1610 x 940 x 500mm equipped with rack for cords (30 fingers)
 - 1 three-phase power console:
 - 1 4-poles thermal magnetic circuit breaker (16A)
 - 1 Emergency stop push button with key
 - 1 Push button + LED indicator
 - 1 3-phase output 3x 400V+N+E on 4mm safety terminals
 - 2 230Vac sockets (2P + E)
 - 12 230Vac sockets (2P + E) with ON indicator (back side)
- Mains power supply 230V - 50/60Hz. 3-metre lead with plug 2P+E.

STUDY OF THE BEHAVIOUR OF A MACHINE IN HYPO AND HYPERSYNCHRONY

An asynchronous motor can convert mechanical energy into electrical energy. To perform this conversion, it has to be driven above the synchronous speed. QUICK-IPLUS is a set of modules of measurement (H-250mm) of switching and 2 asynchronous motors mounted on the same axis of rotation for studying hypersynchrony. The speed controller module drives the first motor above its synchronous speed so that the second becomes a three-phase generator. A central zero wattmeter module indicates the direction of the electrical energy consumed or fed in the case of feeding into the grid. A central 0 phase-meter module demonstrates the change of power factor according to the addition of capacitors or speed variation.



Sockets on the back of the console for connecting the modules



ref. QUICK-IPLUS

ref. QUICK-I without frame and console

TEACHING RESSOURCES STUDENT & TEACHER

EDUCATIONAL OBJECTIVES

- Study the hyposynchronous and hypersynchronous operations of an asynchronous motor.
- Study the effect of a battery of capacitors on the power factor value.
- Study the synchronisation with the national grid.
- Study energy use at an isolated site.
- Calculate the efficiencies of an energy production system.
- Use a clamp ammeter.

Proposed Practical Works

- Procedure of synchronization with the national grid.
- Hyposynchronous and hypersynchronous measurement.
- Reading power factor using a battery of capacitors and consequences.
- Plot of the electrical characteristics of the energy production system.
- Calculation of the overall efficiency.
- Study of the operation at an isolated site.

Comprises

- 1 Single-phase power supply module 230V AC with RC circuit-breaker and emergency stop button.
 - 1 Speed controller module 1500W. Single-phase power supply 230V AC, motor supply output 3 x 230V AC. Adjustment of the rotation frequency by potentiometer on the front.
 - 1 Three-pole cut-out module.
 - 2 digital display modules: Current - Voltage
 - 1 Module with central zero analogue display of the power.
 - 1 Module with central 0 analogue display of power factor.
 - 1 Start/Stop switch module for synchronizing with the electricity grid 3x230/400V.
 - 1 Set of rotating machinery: 2 asynchronous motors 1500W, 3x 230/400V.
 - 1 Resistive load 2000W.
 - 1 Capacitive load 2000 kVAR.
 - 1 set of safety leads for carrying out the different practical works.
 - 1 frame with wheels (H x W x D): 2000 x 1490 x 750mm equipped with a rack for cords (30 fingers) and a melamine tablet 19mm
 - 1 three-phase power console:
 - 1 4-poles thermal magnetic circuit breaker (16A)
 - 1 Emergency stop push button with key
 - 1 Push button + LED indicator
 - 1 3-phase output 3x 400V+N+E on 4mm safety terminals
 - 2 230Vac sockets (2P + E)
 - 12 230Vac sockets (2P + E) with ON indicator (back side)
- Mains power supply 230V - 50/60Hz. 3-metre lead with plug 2P+E.

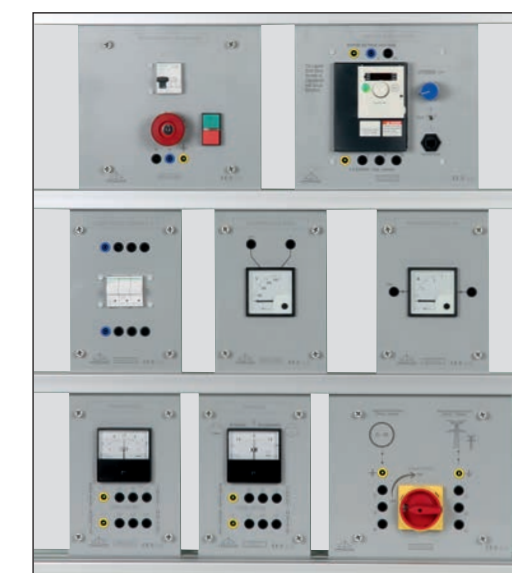

The set can be supplied without the motor set, without capacitive or resistive load, please ask for details.

STUDY OF A SINGLE-PHASE TRANSFORMER 230V-140VA

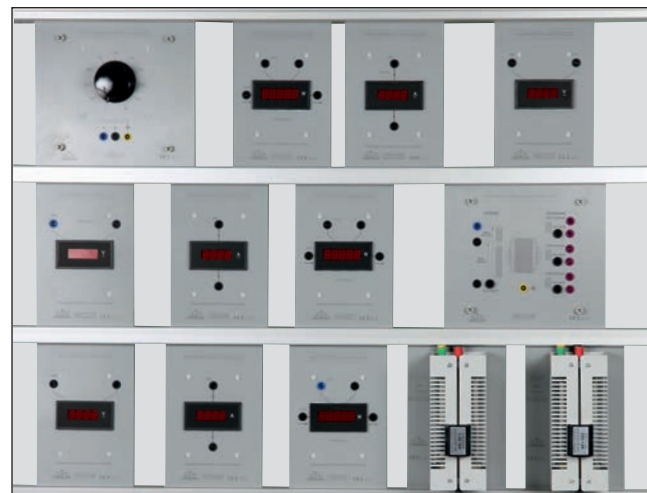

QUICK-G is a set of modules (H-250mm) for studying a compensated single-phase transformer 230V with three secondary windings.

ref. QUICK-GPLUS

ref. QUICK-G
without frame and console

TEACHING RESSOURCES
STUDENT / TEACHER

EDUCATIONAL OBJECTIVES

- Study a single-phase transformer with no load, in short-circuit and loaded.
- Measurement of the different electrical values at the primary and secondary windings.
- Calculation of the powers, efficiency, transformation ratio, and losses of the transformer.

Proposed Practical Works

- Creation of the wiring diagram with measuring devices.
- Study of the use of the compensation winding at the primary.
- Readings of the electrical values of the transformer with no-load.
- Readings of the electrical values of the transformer with load.
- Calculations of the electrical characteristics, power and the transformation ratio.
- Plots of the curves of electrical power and efficiency.

Comprises

- 1 Variable autotransformer module 0-250V AC - 5A.
 - 1 Single-phase transformer module 140VA.
 - 3 Voltage digital display modules.
 - 3 Current digital display modules.
 - 3 Power digital display modules.
 - 1 Variable rheostats module 0-22 ohms.
 - 1 Variable rheostats module 0-3.3 ohms.
 - 1 set of safety leads for carrying out the different practical works.
 - 1 frame with wheels: H1610 x W940 x D500mm equipped with rack for cords (30 fingers)
 - 1 single-phase power console:
 - 1 thermal magnetic circuit breaker (16A)
 - 1 Emergency stop push button with key
 - 1 Push button + LED indicator
 - 1 230V single-phase output on 4mm safety terminals
 - 2 230Vac sockets (2P + E) + 12 230Vac sockets (2P + E), at the back
- Mains power supply 230V - 50/60Hz. 3-metre lead with plug 2P+E.

STUDY A RADIO ALARM



ref. QUICK-ALR

ref. QUICK-ALRPLUS-C communicating version

TEACHING RESSOURCES STUDENT / TEACHER

AUTONOMOUS WIFI

QUICK-ALRPLUS is a group of modules (H-250mm) which provides a study of an anti-intrusion wireless radio.

EDUCATIONAL OBJECTIVES

- Understand and set an anti-intrusion alarm manager
- Understand and learn programming of radio components
- Program different parts of an anti-intrusion alarm such as the center, the detectors, the IT code keyboard, remote commands and the siren.

Possible practical works

- Identification and functionality of each component
- Install components in the architectural blueprint of an apartment.
- Program the alarm center with a presence detector and remote control.
- Program the alarm center with the addition of an IT keyboard and a second presence detector.
- Fixing a facility.

Comprises

- 1 2-zone radio central module.
- 1 outdoor siren module. (Reduced decibel level)
- 1 radio keypad module for receiving information and remote control, with LCD display, switching on and off. Full on and partial on 3 access codes: 1 master, 2 users. History of the last 200 events. System status information: in and out of service, status of detectors, etc. Siren test. System configuration.
- 2 infrared presence detector modules. Range 12m.
- 1 module with two detachable 4-key radio remote controls. Range 100 to 300m.

"INTELLIGENT HOME" ENERGY CONTROL SYSTEM



ref. QUICK-NRJPLUS

SUPPLIED CONFIGURED

AUTONOMOUS WIFI NETWORK

TEACHING RESSOURCES STUDENT / TEACHER

ELECTRICAL COMPONENTS SIMULATED

EDUCATIONAL OBJECTIVES

- Study a measurement system for energy consumption according to new standard for energy saving.
- Study the principle of a home control installation equipped with DELTA DORE® radio components
- Parameter the DELTA DORE® radio components (RF technology)
- Produce wiring for home components.
- Learn how to use a clamp ammeter.

Proposed Practical Works

- Production of the complete wiring diagram.
- Study of the production of the wiring and programming of the components from the DELTA DORE touch screen module
- Study and production of radio commands for lighting, roller blinds and heating.
- Reading of power according to the heating operating cycles.
- Comparison of the power displayed on screen with that calculated from the different readings.
- Creation of scenarios according to the outside temperature and sunshine.

More and more standards and directives require individual homes to be equipped with a system enabling energy consumption to be measured or estimated. QUICK-NRJ groups all the DELTA DORE® components needed to learn about electrical energy consumption. A colour touch screen module displays all the energy use information as graphs. The different components are prepared in plastic housings engraved and equipped with 4mm terminals to facilitate and make safe the wiring using safety leads. The modules are very easy to install on the aluminium wheeled frame.

Comprises

- 1 Module - data transmitter with off-peak hours control
- 1 Module - colour touch screen displaying all the detail of consumption, for controlling heating (pilot wire and load shedding), lighting and roller blinds.
- 1 Module - 3 current transformers (max 60A) for measuring 3 different circuits.
- 1 Module - power interface technical unit for touch screen.
- 1 Radio module - sunlight sensor.
- 1 Radio module - outside temperature sensor
- 2 Radio modules - roller blind control
- 1 Simulation module - 2 blinds.
- 1 Radio module - lighting variation.
- 1 Radio module - lighting variation, off/on, timing
- 2 Modules - bulkhead lights 230V AC - 60 W
- 3 Modules - load 320 W + indicator lights
- 1 Simulation module - 3 pilot wire convactor heaters, 1 hot water tank and 1 pellet burner.
- 1 frame with wheels (H x W x D): 1610 x 940 x 500mm equipped with rack for cords (30 fingers)
- 1 single-phase power console:
 - 1 thermal magnetic circuit breaker (16A)
 - 1 Emergency stop push button with key
 - 1 Push button + LED indicator
 - 1 230V single-phase output on 4mm safety terminals
 - 2 230Vac sockets (2P + E) + 12 230Vac sockets (2P + E), at the back
- 1 set of safety leads for carrying out the different practical works.



Sockets on the back of the console for connecting the modules

The colour touch screen module displays all the detail of consumption, for controlling heating (pilot wire and load shedding), lighting and roller blinds.



STUDY OF ELECTRICAL RADIO INSTALLATION – COMPLETE SOLUTION

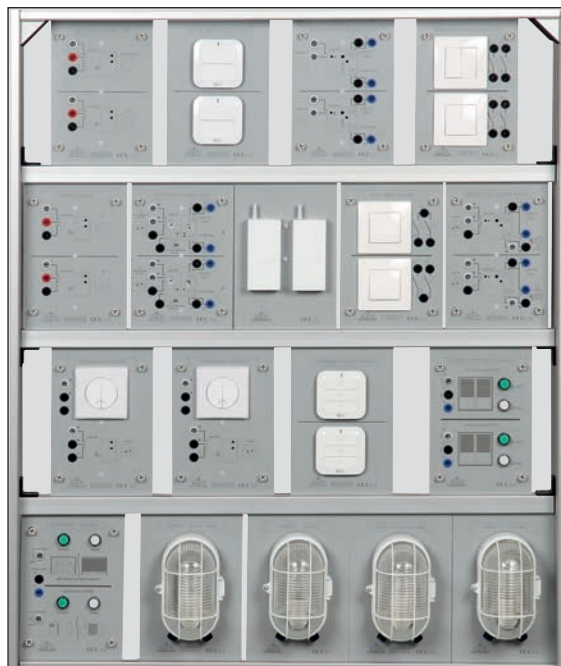

Set of modules (H 250mm) for studying home automation with DELTA DORER® radio components. For the student to learn about radio configuration, the transmitter and receiver modules are instructively put in plastic boxes with the fronts engraved and equipped with terminals diameter 4mm. The various components of the lighting and opening controls are controlled by conventional domestic switches and pushbuttons and by radio switches.

EDUCATIONAL OBJECTIVES

- To learn about home automation.
- To study the compatibility of conventional lighting controls with radio controls.
- To study the wiring and configuration of communicating components.
- To study the programming of and the DELTA DORE radio solution

Réf. QUICK-PPLUS

Réf. QUICK-PPLUS without frame and console



Proposed Practical Works

- Radio programming of four lighting circuits by pushbutton, two-way and double lighting.
- Wiring of four lighting circuits with conventional and radio switches.
- Radio programming of opening and closing of two roller blinds, gate and garage.
- Creation of several operating scenarios.

Comprises

- 1 domestic double pushbutton and double switch module.
- 1 module with 2 double transmitter switches.
- 1 module with 2 lighting control receivers.
- 1 module with 2 double transmitter switches for roller blinds.
- 1 transmitter module for roller blinds with domestic pushbutton.
- 1 module with 2 domestic two-way switches.
- 1 transmitter module for garage opening with domestic pushbutton.
- 1 module with 2 lighting variation control receivers.
- 2 modules with 2 transmitters for pushbutton and switch.
- 1 module with 2 receivers of gate and garage opening/closing controls.
- 1 simulation module of gate and garage opening/closing with diagram and indicator light signalling
- 1 simulation module of 2 roller blinds with diagram and indicator light signalling
- 1 module with 2 receivers of roller blind controls.
- 4 lighting modules with Bulkhead lights 60W – 230VAC
- 1 frame with wheels (H x W x D): 1610 x 940 x 500mm equipped with rack for cords (30 fingers)
- 1 single-phase power console:
 - 1 thermal magnetic circuit breaker (16A)
 - 1 Emergency stop push button with key
 - 1 Push button + LED indicator
 - 1 230V single-phase output on 4mm safety terminals
 - 2 230Vac sockets (2P + E) + 12 230Vac sockets (2P + E), at the back
- 1 set of safety leads for carrying out the different practical works.

ADD COMMUNICATING MODULE FOR SMARTPHONE AND TABLET

Wi-Fi / Radio Interface Set with RJ45 Wifi Switch. Allows to communicate from a tablet or Smartphone a RADIO Delta Dore set. Connection to 2P + T 230VAC socket.



ref. COM-DEL

Autonomous subassemblies of radio installation

On frame ref. SUP-AK. Height 610mm – Width 590mm.



Study of radio lighting control

- 1 single-phase power module with MT circuit-breaker 16A.
- 1 domestic double pushbutton and double switch module.
- 1 module with 2 transmitters for pushbutton and switch.
- 1 module with 2 double transmitter switches.
- 1 module with 2 lighting control receivers.
- 1 lighting module with 2 Bulkhead lights 60W – 230VAC.

ref. QUICK-AK6 with frame

ref. QUICK-AK6-N without frame

Study of radio lighting variation control

- 1 single-phase power module with MT circuit-breaker 16A.
- 1 module with 2 domestic double pushbuttons.
- 1 module with 2 transmitters for pushbutton
- 1 module with 2 double transmitter switches.
- 1 module with 2 lighting variation control receivers.
- 1 lighting module with 2 Bulkhead lights 60W – 230VAC.

ref. QUICK-AK7 with frame

ref. QUICK-AK7-N without frame



Study of radio roller blind control

- 1 single-phase power module with MT circuit-breaker 16A.
- 1 simulation module of 2 roller blinds with diagram and indicator light signalling
- 1 module with 2 double transmitter switches for roller blinds.
- 1 module with 2 receivers of roller blind controls.
- 1 transmitter module for roller blinds with domestic pushbutton.

ref. QUICK-AK8 with frame

ref. QUICK-AK8-N without frame

STUDY SYSTEM FOR THE KNX BUS - COMPLETE SOLUTION



Réf. QUICK-KNXPLUS

Réf. QUICK-KNX without frame and console

SUPPLIED CONFIGURED TEACHING RESSOURCES STUDENT / TEACHER ELECTRICAL COMPONENTS SIMULATED



Sockets on the back of the console for connecting the modules

With "KNX PARTNER" certified manufacture, the QUICK-KNX model enables the study and putting into service of multibrand KNX products, SCHNEIDER® and HAGER® (other on request). The KNX devices are prepared in plastic housings with the front engraved and equipped with Ø4mm terminals.

EDUCATIONAL OBJECTIVES

- Studying KNX communication media
- Studying the principle of a home control installation with KNX devices
- Configuration of KNX devices
- Creating the wiring of KNX devices
- Creating home control scenarios

Proposed Practical Works

- Creation of the complete wiring diagram
- Study the creation of KNX wiring and programming for the functions of lighting control, shutter and opening control using pushbuttons
- Creation of home control scenarios like using a single key to switch off the lights, lower the blinds and open the garage door and the gate
- Combine several different brands makes with the same KNX standard

Comprises

- 1 30V power supply module for the bus
- 1 USB interface module for programming from a PC
- 2 4-key pushbutton modules with indicator lights (1 per brand)
- 1 2-key pushbutton module with indicator lights
- 1 universal pushbutton interface module
- 1 Presence detector module
- 1 4-output switch actuator module
- 1 2-outputs switch actuator module
- 1 2-outputs control actuator module
- 1 1-outputs control actuator module
- 1 2-outputs roller blind actuator module
- 1 Module with printing and signalling for two roller blinds
- 1 Module with printing and signalling for opening / closing gate and garage
- 4 Modules for bulkhead lights 60W – 230VAC
- Software ETS lite
- 1 frame with wheels (H x W x D): 1610 x 940 x 500mm equipped with rack for cords (30 fingers)
- 1 single-phase power console:
 - 1 thermal magnetic circuit breaker (16A) - 1 Emergency stop push button with key
 - 1 Push button + LED indicator - 1 230V single-phase output on 4mm safety terminals
 - 2 230Vac sockets (2P + E) + 12 230Vac sockets (2P + E), at the back
 - 1 set of safety leads for carrying out the different practical works.

HEAT SENSOR HAGER® LIGHT SENSOR SCHNEIDER®

ref. DOMO-4

SMARTPHONE CONTROL LOT

ref. COM-KNX

- InSideControl gateway module with power supply
- WiFi switch module

The InSideControl gateway links the KNX installation to the IP network (LAN). Up to 5 smartphones / tablets can control the installation using the InSideControl App/HD App, available for IOS and Android. The gateway can be used as access interface to the bus (e.g. for. The functionalities of the application are configured with the InSideControl Builder software supplied. Smartphones or tablets communicate with KNX devices by WiFi. Smartphone and InSideControl App/HD App are not supplied with the lot.

KNX HEATING CONTROL LOT

- 2-key pushbutton module with indicator light.
- Thermostat module with programming screen + keys.
- 2-output switch actuator module.
- Resistive load module 320W – 230VAC + indicator light.

ref. DOMO-1

KNX TOUCH SCREEN CONTROL LOT

- The touch screen is used to view the states and control the KNX functionalities
- 7" touch screen (17.8cm) 65000 colours.
 - Power supply 230VAC 50-60Hz.
 - USB port
 - LAN interface (10/100 Mbit/s)

ref. DOMO-2

Study of the KNX bus – Autonomous subassemblies

On frame ref. SUP-AK. Height 610mm – Width 590mm.

Study of lighting control by pushbutton

- 1 bus power supply module 30V + USB interface.
- 1 pushbutton module, four keys with indicator lights.
- 1 switch actuator module, 2 outputs.
- 2 Bulkhead lighting modules 60W – 230VAC.

ref. QUICK-AK1 with frame

ref. QUICK-AK1-N without frame

Study of variation lighting control by pushbutton

- 1 bus power supply module 30V + USB interface.
- 1 4-key pushbutton module with indicator lights.
- 1 variation actuator module, 2 outputs.
- 2 Modules for bulkhead lights 60W – 230VAC.

ref. QUICK-AK2 with frame

ref. QUICK-AK2-N without frame

Study of lighting control by presence detector

- 1 bus power supply module 30V + USB interface.
- 1 presence detector module.
- 1 switch actuator module, 2 outputs.
- 2 Modules for bulkhead lights 60W – 230VAC.

ref. QUICK-AK3 with frame

ref. QUICK-AK3-N without frame

Study of roller blind control by pushbutton

- 1 bus power supply module 30V + USB interface.
- 1 4-key pushbutton module with indicator lights
- 1 roller blind actuator module, 2 outputs.
- 1 module with diagram and signalling of two roller blinds.

ref. QUICK-AK4 with frame

ref. QUICK-AK4-N without frame

Study of opening control of gate and garage door

- 1 bus power supply module 30V + USB interface.
- 1 4-key pushbutton module with indicator lights.
- 1 switch actuator module, 2 outputs.
- 1 module with diagram and signalling, opening/closing gate and garage.

ref. QUICK-AK5 with frame

ref. QUICK-AK5-N without frame

STUDY OF DIFFERENT LIGHTS WIRINGS



ref. QUICK-APLUS

ref. QUICK-A without frame and console

TEACHING RESSOURCES STUDENT / TEACHER

Set of modules (H-250mm) for studying the different types of wiring of lights. The modules are cabled using safety leads Ø4mm.



Sockets on the back of the console for connecting the modules

EDUCATIONAL OBJECTIVES

- Study of house wiring diagrams.
- Study and operation of a single lighting circuit.
- Study and operation of a double lighting circuit.
- Study and operation of a two-way circuit.
- Study and operation of a remote control switch circuit
- Study and operation of a timer circuit.
- Study and operation of a dusk switch circuit.
- Study and operation of an energy meter.

Proposed Practical Works

- Creation of house lights wiring diagrams.
- Creation of different light wiring such as single, double, two-way, timer, remote control, dusk switch.
- Creation of energy meter wiring.
- Creation of reading of light power consumption.

Comprises

- 1 Module – Two pushbuttons
- 1 Module – Two-way switch
- 1 Module - Two single lighting switches
- 1 Module – Two double lighting switches
- 1 Module – Single phase energy meter 63A
- 1 Module – Circuit-breaker 1P+E 16A
- 1 Module – Residual current circuit-breaker 30mA
- 1 Module – Timer, coil 230VAC-50Hz
- 1 Module – Remote control switch, coil 230VAC-50Hz
- 1 Module – Dusk switch + photocell
- 1 Module – Analogue ammeter 2.5A and Analogue voltmeter 250VAC
- 4 Modules – Bulkhead lights 230VAC-40W
- 1 set of safety leads for carrying out the different practical works.
- 1 frame with wheels (H x W x D): 1610 x 940 x 500mm equipped with rack for cords (30 fingers)
- 1 single-phase power console:
 - 1 thermal magnetic circuit breaker (16A)
 - 1 Emergency stop push button with key
 - 1 Push button + LED indicator
 - 1 230V single-phase output on 4mm safety terminals
 - 2 230Vac sockets (2P + E) + 12 230Vac sockets (2P + E), at the back

Lights wirings - Autonomous sub-assemblies

Height 610mm - Width 590mm.

Each reference is delivered with a set of safety ropes to wire different modules.
General power supply with 230VAC 1.5m mains wires.

Study a double lighting circuit with switches

- 1 230V power module on 4m terminals with a 16A magneto-thermal circuit breaker and viewing window.
- 2 switch modules
- 2 lighting modules with windows, 60W-230VAC.

ref. QUICK-AK11 with frame



Study a lighting circuit with a push-button and contactor

- 1 230V power module on 4m terminals with a 16A magneto-thermal circuit breaker and viewing window.
- 2 push-button modules.
- 1 contactor module, 230V.
- 2 lighting modules with windows, 60W-230VAC

ref. QUICK-AK12 with frame



Study a lighting circuit with back-and-forth switches

- 1 230V power module on 4m terminals with a 16A magneto-thermal circuit breaker and viewing window.
- 2 back-and-forth switch modules.
- 2 lighting modules with windows, 60W-230VAC

ref. QUICK-AK13 with frame



Study a lighting circuit with a timer-type staircase

- 1 230V power module on 4m terminals with a 16A magneto-thermal circuit breaker and viewing window.
- 2 push-button modules.
- 1 timer module, 230V, timer-type staircase.
- 1 lighting module with 1 window, 60W-230VAC.

ref. QUICK-AK14 with frame

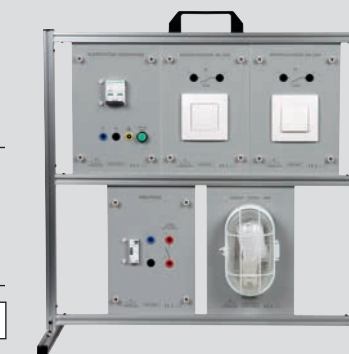

Study a lighting circuit with a dusk-to-dawn switch

- 1 230V power module on 4m terminals with an MT16A circuit breaker and viewing window.
- 1 switch module.
- 1 dusk-to-dawn switch, 230V, with a sensor.
- 1 lighting module with 1 window, 60W-230VAC.

ref. QUICK-AK15 with frame



Study a two-roller shutter

- 1 230V power module on 4m terminals with an MT16A circuit breaker and viewing window.
- 2 switch modules for two-roller shutter control.
- 1 simulation module of two-roller shutter with elevate and descent viewing windows.

ref. QUICK-AK16 with frame



STUDY AN IP CAMERA



Comprises

- 1 DVR AHD video recorder, 8 video inputs Full-HD, 120 IPS, HDD and 1TB. Integrated web server for video configuration and playing. Viewing of the images from the 4 cameras simultaneously on the monitor.
- 2 adjustable AHD cameras, 1/2.8" CMOS sensor, 36 infrared LED's for night vision, resolution: FULL HD (1080p),
- 2 adjustable IP Easy cameras, 1/4" CMOS sensor, 30 infrared LED's for night vision, resolution: HD (720p), 30 IPS, Supplied with IP/BNC connector.
- 1 15.6" LED monitor. HD Resolution.
- 1 230V outlet worktop for connecting all the devices.
- 1 RJ45 switch.
- 1 frame H x L x l : 610 x 590 x 310mm

ref. QUICK-CIPLUS

SUPPLIED CONFIGURED

AUTONOMOUS WIFI NETWORK

TEACHING RESSOURCES STUDENT / TEACHER

Provides study of hybrid analog and IP Easy video surveillance. The student can set interconnections to BNC and Ethernet wires.

He will be able to configure addressing, settings for different cameras, and visualization of different camera images. Recording on detection or by time range. Electrical energy-independent system.

Images of different cameras can be directly visualized on a tablet or smartphone using an integrated WiFi network.

EDUCATIONAL OBJECTIVES

- Understand and configure a set of video surveillance components.
- Wire a hybrid analog and IP easy network
- Make electrical diagrams
- Create the wiring and physically connect various electrical components
- Produce a parts list and analyze manufacturer sheets
- Understand configuration, programming from an integrated Web server.
- Configure an Ethernet computer network.
- Carry out the commissioning of the installation
- Perform recording settings

Possible practical work

- Setting up the recorder and the computer for the connection on the webserver.
- Cabling of a Hybrid network
- Realization of the wiring of the analog cameras
- Realization of the cabling of the IP cameras
- Realization of the wiring of the recorder
- Realization of wiring diagrams
- Camera settings.
- Setting up remote viewing
- Configuration of the recording schedule
- Viewing of a recording made by the surveillance cameras

STUDY OF TEMPERATURE REGULATION BY PID



Modules (H-250mm). Frame : H610mm - L500mm.

Powered by 230VAC sector 1.5m cord.

EDUCATIONAL OBJECTIVES

- Learn about and wire a system of temperature regulation by PID.
- Study, configure, and control a PID regulator.
- Study an analogue signal 4-20mA.
- Study a PT100 temperature sensor signal.
- Use a dimmer 230V, 4-20mA.

Proposed Practical Works

- Creation of the complete wiring diagram of the temperature regulation system.
- Configuration of the PID regulator for an analogue signal 4-20mA.
- Temperature regulation according to several set points.

Comprises

- 1 DC power supply module 230V AC, 24V DC - 3A.
- 1 PID temperature regulator module. Self-adjusting and manual. 4-digit display for set point, input and output 4-20mA. Binary alarm output.
- 1 PT100 temperature sensor module. Three wires.
- 1 PT100 signal converter module, 4-20mA.
- 1 Indicator light module 230V AC
- 1 Single-phase power dimmer module. Variation of the thyristor conduction angle according to the control current 4-20mA.
- 1 Heating unit module equipped with a 60W lamp powered at 230VAC. Thanks to two supports, the temperature sensor can be put into the unit.
- 1 set of safety leads for carrying out the different practical works.
- Mains power supply 230V - 50/60Hz. 3-metre lead with plug 2P+E.

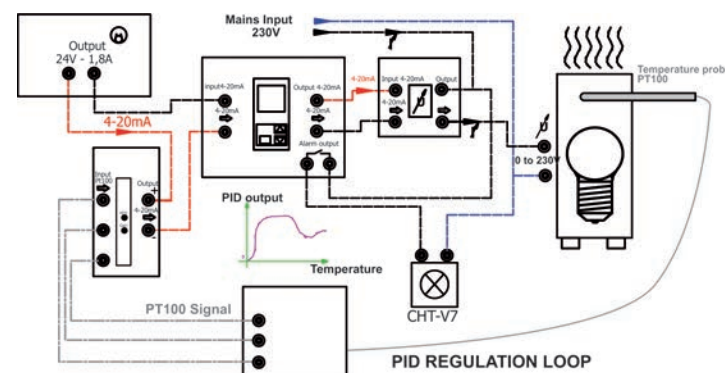

ref. QUICK-K with frame

ref. QUICK-K-N without frame

ref. QUICK-KS communicating with frame

ref. QUICK-KS-N communicating without frame

TEACHING RESSOURCES STUDENT / TEACHER



STUDY OF ALL OR NOTHING TEMPERATURE REGULATION



Modules (H-250mm). Frame : H610mm - L500mm.

Powered by 230VAC sector 1.5m cord.

EDUCATIONAL OBJECTIVES

- To learn about & cable one system of all or nothing temperature regulation
- To study, configure and control an all or nothing regulator.
- To recover data by computer (communicating version)
- To discover the resistance / temperature relationship as measurement principle

Proposed Practical Works

- Creation of the wiring diagram of the regulation system.
- Configuration of the regulator.
- Observation of temperature regulation phenomena.

Comprises

- 1 all or nothing regulator module. With display. Communicating for QUICK-OS version by USB lead (software supplied).
- 1 temperature probe PT100 module + Signal converter PT100 / 4-20mA. 1 heating unit module equipped with lamp 60W powered at 230VAC. The temperature probe can be put into the unit thanks to two supports.
- 1 indicator light module 230VAC.
- 1 set of safety leads for carrying out the different PAs.

ref. QUICK-O with frame

ref. QUICK-O-N without frame

ref. QUICK-OS communicating with frame

ref. QUICK-OS-N communicating without frame

TEACHING RESSOURCES STUDENT / TEACHER

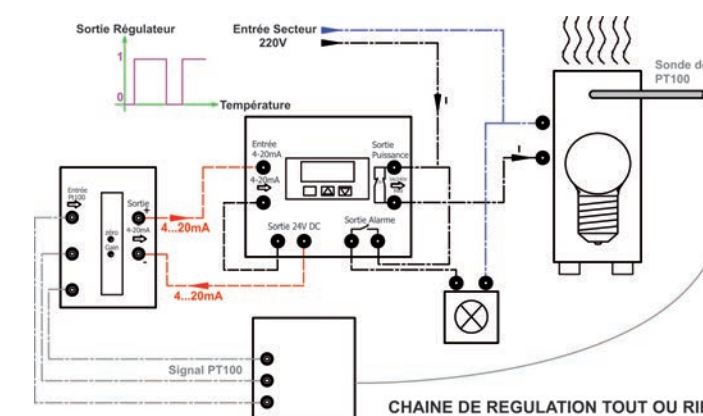
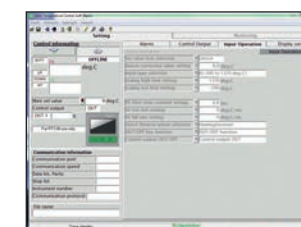

STUDY OF REGULATION OF LEVEL BY PID



ref. QUICK-NDPLUS

ref. QUICK-NIVPLUS Version without flow rate regulation

TEACHING RESSOURCES STUDENT / TEACHER

The system is delivered fully configured and functional.

Complete pedagogical file on CD with technical user's manuals, a course on the regulation and student/teacher practical works.
1 set of safety leads for carrying out the different practical works.



Set of modules associated with an operative part for studying the water level regulation by PID and 4-20mA hydrostatic sensor.

EDUCATIONAL OBJECTIVES

- Putting an electrical installation into service.
- To learn about and use a PID regulator, a hydrostatic sensor, and a 4-20mA flowmeter.
- To use a regulation system for water level and flow rate by analogue signal 4.20mA.
- To use and configure a speed drive locally and from programming software.
- To measure, analyse and interpret analogue signals.
- To learn industrial maintenance.

Practical works

- General theoretical lessons on regulation
- Identification of the different components of the regulation system for water level and flow rate
- Configuring the speed drive
- Configuring the PID regulator
- Measuring the current 4-20mA at the input of the PID and at the output of the speed drive

Comprises

- 1 single-phase power supply module with 30mA/16A residual current and thermal magnetic circuit-breaker, an emergency stop button and a main ON/OFF button with indicator light. Power supply of the module by 2P+E plug and 2 metres mains lead. 230VAC on 3 safety terminals for powering the modules on the front panel.
- 1 single-phase 230VAC/ 3-phase 230VAC speed controller module. Adjustment by potentiometer, 4-20mA input and RJ45 connector for the configuration from SoMove software delivered with the system.
- 1 thermal relay module
- 1 230VAC/24VDC power supply module
- 1 PID regulator 4-20mA. Self-regulating and manual. 4 digits display for the setpoint value and the configuration.
- 1 frame with wheels (H x W x D): 1610 x 940 x 500mm equipped with rack for cords (30 fingers)
- 1 single-phase power console:
 - 1 thermal magnetic circuit breaker (16A)
 - 1 Emergency stop push button with key
 - 1 Push button + LED indicator
 - 1 230V single-phase output on 4mm safety terminals
 - 2 230Vac sockets (2P + E) + 12 230Vac sockets (2P + E), at the back
- Mains power supply 230V - 50/60Hz. 3-metre lead with plug 2P+E.

Composition of the operative part

- A bottom tank of 100L.
- One top tank of 60L with 2 transparent sides. One tape rule on one side for monitoring the water level. One inner wall of the tank for preventing eddies.
- One three-phase motor pump 230V/400V with 750W capacity.
- One rotary valve for manually adjusting the water flow rate at the pump outlet.
- One rotary valve for adjusting the water leak level at the tank outlet.
- One ¼ turn valve for rapid draining of the tank.
- One 4-20mA flowmeter with integrated digital display. Pushbuttons on the front of the sensor enable its programming.
- One hydrostatic pressure sensor 4-20mA directly mounted on the tank wall. Measuring range 0-600mm.
- 1 power console equipped with 4mm safety terminals for the connection of the modules with 4mm safety leads.

STUDY OF PNEUMATIC COMPONENTS

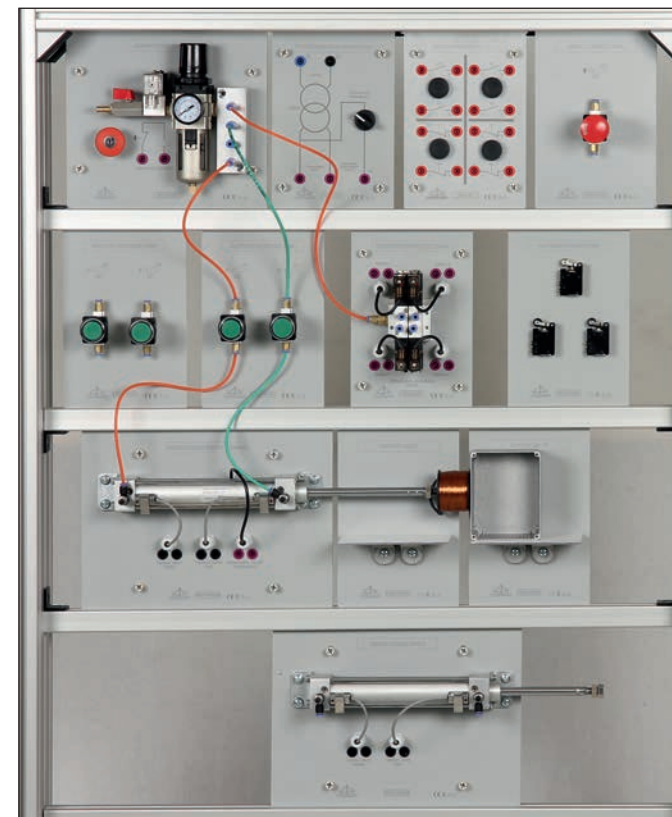

ref. QUICK-PN1PLUS

ref. QUICK-PN1 without frame and console

TEACHING RESSOURCES STUDENT / TEACHER



Sockets on the back of the console for connecting the modules

Sets of modules (H 250mm) for studying pneumatic automation.

Comprised of cylinders, electropneumatic distributors, pneumatic controls that can be connected via pneumatic quick-fit connectors 4mm and safety terminals Ø4mm for electrical connection at 24V.

EDUCATIONAL OBJECTIVES

- To study the symbols used to represent pneumatic components
- To study the operation of a double-acting cylinder
- To study the operation of a double-acting cylinder with electromagnet
- To study the wiring of pneumatic and electropneumatic automation

Proposed Practical Works

- Creation of pneumatic automation diagram
- Study of the operation of a pneumatic double-acting cylinder, with pressure adjustment to optimize displacement.
- Study of the operation of a pneumatic cylinder with electromagnet.
- Study of a pneumatic and electropneumatic distributor.

Comprises

- 1 pneumatic distributor module with 4 outputs, with manometer, filter, pressure regulator, coil 24VAC and emergency stop. Quick-fit connections for hose 4mm.
- 1 safety transformer module 220VAC/24VAC with on/off switch for electromagnet power supply.
- 1 pneumatic emergency stop module with quick-fit connections for hose 4mm.
- 2 modules of 2 pneumatic pushbuttons with quick-fit connections for hose 4mm.
- 1 module of 3 pneumatic limit switches with quick-fit connections for hose 4mm.
- 1 module of 2 electropneumatic distributors 5/2. Coils 24VAC with quick-fit connections for hose 4mm
- 2 part support modules with 1 metal box.
- 1 pneumatic double-acting cylinder module. With quick-fit connections with pressure variation for hose 4mm. 2 Position detectors.
- 1 pneumatic double-acting cylinder module. With quick-fit connections with pressure variation for hose 4mm. 2 Position detectors and one electromagnet 24VAC.
- 1 frame with wheels (H x W x D): 1610 x 940 x 500mm equipped with rack for cords (30 fingers)
- 1 single-phase power console:
 - 1 thermal magnetic circuit breaker (16A)
 - 1 Emergency stop push button with key
 - 1 Push button + LED indicator
 - 1 230V single-phase output on 4mm safety terminals
 - 2 230Vac sockets (2P + E) + 12 230Vac sockets (2P + E), at the back
- 1 set of safety leads for carrying out the different practical works.

COMPRESSOR OPTION

Four oil-free cylinders compress clean air into a tank which maintains a stable steady pressure. Each cylinder has a filter. A regulator and pressure gauge enable service pressure adjustments from a few tenths of a bar to the maximum tank pressure. The latter can be selected between two values: 4 bars with motor shutdown by pressure switch or 6 bars in continuous operation. The compressor has thermal protection. Very low sound nuisance.

- Flow rate: 70 l/min
- Connection: 4mm
- Pressure adjustable from 0 to 6 bars
- Tank volume: 4 litres
- Power: 180W
- Sound level: 70dBA (very low sound nuisance)
- Power supply: 230V AC 50Hz
- Dimensions: 385 x 205 x 325mm - Weight: 8.4kg

ref. PRESS-35



STUDY OF THE PROGRAMMING OF PLC AND HMI (HUMAN MACHINE INTERFACE)

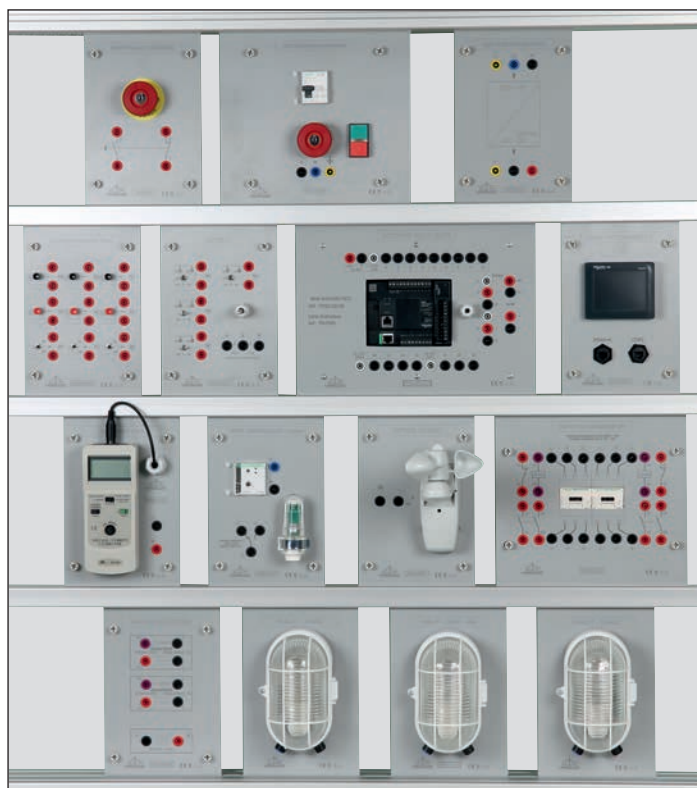

Sets of modules (H-250mm) and sensors for studying a PLC with touch screen

ref. QUICK-DPLUS (Siemens)

ref. QUICK-D without frame and console

TEACHING RESSOURCES STUDENT / TEACHER

ref. QUICK-EPLUS (Schneider)

ref. QUICK-E without frame and console

TEACHING RESSOURCES STUDENT / TEACHER AUTONOMOUS WIFI NETWORK

EDUCATIONAL OBJECTIVES

- Study of a complete diagram with automation sensors and components for connecting to the inputs/outputs of a PLC.
- Study the configuration of an Ethernet for computers.
- Study the programming of a PLC in contact language.
- Study the programming of an HMI (Human Machine Interface).
- Study an analogue signal by current and voltage.
- Set up a Wifi network and control the components from a tablet (QUICK-ECPLUS only)

Proposed Practical Works

- Creation of the complete wiring diagram of a PLC, an HMI and binary and analogue sensors.
- Creation of the configuration of an Ethernet.
- Creation of a complete PLC program in contact language.
- Creation of a supervision program with control from the HMI.
- Configuration of the PLC with analogue inputs/outputs for 4-20mA and 0-200mV signal.
- Wiring an Ethernet network (QUICK-ECPLUS only)
- Carry out the Wifi configuration (QUICK-ECPLUS only)

Comprises

QUICK-D version : SIEMENS®

- 1 Siemens® PLC module SIMATEC S7-1200 Ethernet 14I/10O binary with 1 input and 1 output 4-20mA. Optional LOG-STEP programming software.
- 1 Siemens HMI module Simatic KTP600 Ethernet 5.7". Optional LOG-STEP programming software.

QUICK-E version : SCHNEIDER®

- 1 Schneider® PLC module M221 Ethernet 14I/10O binary with 1 analog expansion card. Supplied with SoMachine Basic programming software.
- 1 Schneider HMI module HMISTU Ethernet 3.7" colour. Supplied with VigeoDesigner programming software.

Common modules

- 1 Emergency stop module.
- 1 Distribution module of 230VAC on 4mm terminals with RC circuit-breaker 30mA-16A.
- 1 Power supply module 230V AC - 24V DC - 2A.
- 1 Pushbutton and switch module.
- 1 Module with limit switch and PT100 temperature sensor.
- 1 Signal generator module 0-10V and 0-200mV.
- 1 Light sensor module.
- 1 Wind sensor module.
- 1 Voltage dimmer module 230V AC with analogue input 4-20mA.
- 1 Module with 2 auxiliary contactors 24V DC.
- 1 Indicator light module 24V DC.
- 3 Bulkhead light modules 230V AC, 40W.
- 1 Set of safety leads for carrying out the different practical works.
- 1 frame with wheels (H x W x D): 1610 x 940 x 500mm equipped with rack for cords (30 fingers)
- 1 single-phase power console:
 - 1 thermal magnetic circuit breaker (16A)
 - 1 Emergency stop push button with key
 - 1 Push button + LED indicator
 - 1 230V single-phase output on 4mm safety terminals
 - 2 230Vac sockets (2P + E) + 12 230Vac sockets (2P + E), at the back



Sockets on the back of the console for connecting the modules

SIMPLIFIED STUDY OF M221 CONTROLLER



Powered by 230VAC sector 1.5m cord.

ref. QUICK-AK9

TEACHING RESSOURCES STUDENT / TEACHER

ref. QUICK-AK9-C communicating version

TEACHING RESSOURCES STUDENT / TEACHER AUTONOMOUS WIFI NETWORK

EDUCATIONAL OBJECTIVES

- To study the connection diagram of the inputs and outputs of a PLC.
- To study the configuration of a computer Ethernet.
- To study the programming of a PLC in contact language.
- To study the programming of an HMI (Human Machine Interface).
- Carry out a WiFi network configuration for ordering on a tablet or smartphone (QUICK-AK9-C only).

Proposed Practical Works

- Creation of a complete wiring diagram of the programmable logic controller and the HMI.
- Creation of the complete wiring.
- Creation of Ethernet configuration with IP addressing of the PLC, HMI and PC.
- Creation of a complete controller program in contact language.
- Creation of a complete supervision program of the HMI in contact language.
- Pilotage de l'automate depuis tablette ou smartphone (QUICK-AK9-C uniquement)

Comprises

- 1 Schneider® M221 PLC module. Ethernet. 14 I and 10 O all or nothing. Supplied with SoMachine basic software.
- 1 Schneider® HMI Colour 3.7" module. Supplied with the VigeoDesigner supervision software.
- 1 power supply module 24VDC
- 1 pushbutton and switch module.
- 1 module of 10 Indicator lights 24VDC.
- 1 set of safety leads for carrying out the different practical works.

QUICK-AK9-C only

- 1 WIFI router configured for the use of a stand-alone WiFi network specific to the system (no connection to the computer network or WiFi network of your building is required). Allows you to control the PLC remotely via a tablet, a Smartphone, or a PC.



SIMPLIFIED STUDY OF S7-1200 CONTROLLER

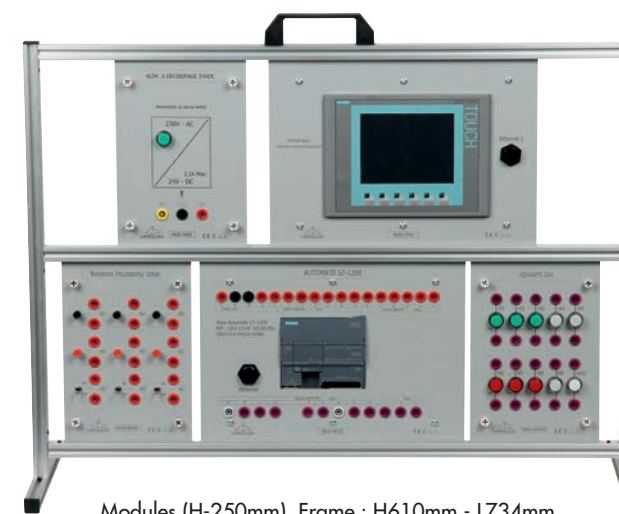

Modules (H-250mm). Frame : H610mm - L734mm.

ref. QUICK-AK91

TEACHING RESSOURCES STUDENT / TEACHER

RECOMMENDED SOFTWARE OPTION

Very intuitive, it offers online help and tutorials allowing the student to become familiar very quickly with the different programming screens.

ref. LOG-STEP

EDUCATIONAL OBJECTIVES

- Study the connection diagram of the inputs and outputs of a PLC.
- Study the configuration of a computer network type Profinet.
- Study the programming of an automaton in ladder language.
- Study the programming of an HMI (Human Machine Interface).

Proposed Practical Works

- Realization of the complete wiring diagram of a programmable automaton, its inputs/outputs, and an HMI.
- Realization of the configuration of an Ethernet network.
- Realization of a complete PLC program in ladder and/or grafcet language.
- Creation of a supervision program with command from the HMI.

Comprises

- 1 frame in aluminum profile.
- 1 PLC module S7-1200 Siemens® Ethernet 14I/10O Discrete with I/O 4-20mA or 0-10V. Connected to the 230VAC mains with cord and 2P+T socket.
- 1 Siemens 5.7-inch color HMI touch screen module
- 1 24VDC power supply module
- 1 pushbutton and switch module.
- 1 module of 10 24VDC LEDs.
- 1 set of safety cords allowing the realization of the different practical exercises.



STUDY OF POWER FACTOR RECTIFICATION



Set of modules for studying the power factor rectification of an electrical installation. The modules are cabled using safety leads Ø4mm. Compatible load 230V-5A Max.

EDUCATIONAL OBJECTIVES

- Study of the power factor.
- Study of the powers.
- Demonstrate the advantage of rectifying power factor on the kWh cost

Proposed Practical Works

- Study of an industrial lighting installation using a fluorescent tube: readings of current, power and voltage in each energy transmission line.
- Creation of the Fresnel diagram using active and reactive powers.
- Study of pure inductance in order to determine the capacitor battery to be installed.
- Study of resonance, max/min current.

ref. QUICK-LPLUS ref. QUICK-L without frame and console

TEACHING RESSOURCES STUDENT / TEACHER

Comprises

- 1 Module – Distribution of single-phase voltage 230VAC-50Hz
- 3 Modules – Digital ammeters 5A
- 1 Module – Digital voltmeter single-phase 230VAC
- 3 Modules – Digital multifunction displays 230VAC-5A. Displays of P/U/I/Power factor.
- 3 Modules – Reactive power 230VAC-5A.
- 1 Module for load connection
- 1 Module – battery of 10 capacitors 0.1 to 41µF with jumpers.
- 1 Module – safety inductance, variable from 0.1 to 1.4H - 2A
- 1 Module – Fluorescent tube 230VAC-18W
- 1 set of safety leads for carrying out the different practical works.
- 1 frame with wheels: H1610 x W940 x D500mm equipped with rack for cords (30 fingers)
- 1 single-phase power console:
 - 1 thermal magnetic circuit breaker (16A)
 - 1 Emergency stop push button with key
 - 1 Push button + LED indicator
 - 1 230V single-phase output on 4mm safety terminals
 - 2 230Vac sockets (2P + E) + 12 230Vac sockets (2P + E), at the back

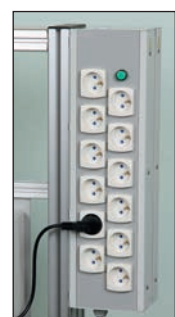

Sockets on the back of the console for connecting the modules

MODULE STORAGE CABINET



- Equipped with 4 shelves forming as well as 5 levels of storage.
- Max load per level: 100 kg
- Revolving handle with lock on the right door.
- Single color: Pearl gray (epoxy paint baked)
- Dimensions: Width: 90mm, Height 1800mm, Depth: 450mm
- Empty weight: 94kg

ref. HB58 (delivered disassembled)

Can contain 80 mods minimum.

MODULE STORAGE RACK



- Matte anodized aluminum frame with 3 storage levels.
- 4 castors including 2 with brakes.
- Dimensions: H-1220 x W-1250 x D-630mm

ref. RANG-MOD

Can contain 80 mods minimum.

STUDY OF THE ROLE OF THE EARTH & A RESIDUAL CURRENT CIRCUIT-BREAKER

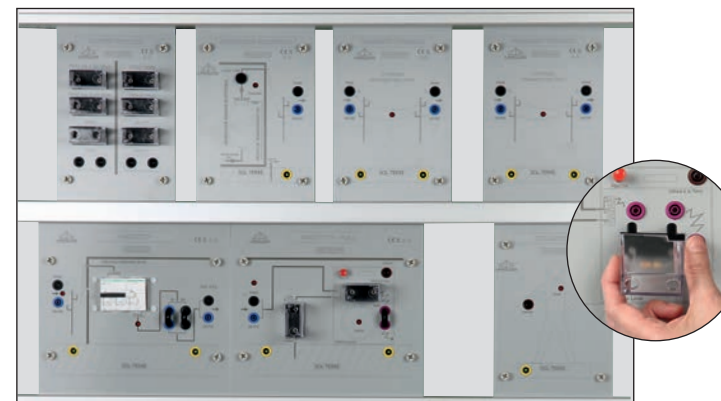

QUICK-H is a set of modules (H250mm) for studying the role of the earth and an RC circuit-breaker.

The synoptic diagrams on the modules show the path of electrical energy from a transformer substation and a house. Resistive dipoles, for insertion in the modules, allow students to simulate two earth resistance values and two fault resistance values.

To prevent any risk of electrocution to the student, the modules operate at extra-low voltage using an isolating transformer to standard NFC61558.



Sockets on the back of the console for connecting the modules

ref. QUICK-HPLUS ref. QUICK-H without frame and console

TEACHING RESSOURCES STUDENT / TEACHER

EDUCATIONAL OBJECTIVES

- Make students aware of electrocution risks in the event of indirect contact.
- Make students aware of risks related to the quality of the earth.
- Explain the role of the RC circuit-breaker 30mA in a domestic installation.

Proposed Practical Works

- Operation of a thermal-magnetic circuit-breaker: rating, breaking capacity, tripping curve, and symbols.
- Operation of an RC circuit-breaker: rating, tripping time, and symbols.
- Physiological effects of the current: risk areas, risk according to the current, and dangerous voltages.
- Maximum resistance of the earth.

Comprises

- 1 Transformer module 230V AC, 24V AC. A printed diagram shows the public network, with its medium/low voltage transformer substation, and the neutral to earth connection in this substation.
- 2 Modules of transmission lines from the transformer substation to a domestic installation.
- 2 Modules with the RC circuit-breaker 30mA, and a washing machine simulation.
- 1 Module with a printed diagram of a person, equipped with a LED on the heart. If a dangerous leakage current flows, the LED comes on.
- 1 Dipole support module. Two earth resistances (100 ohms and 5 ohms), 2 fault resistances (10 ohms and 2 kohms) and four blanks so you can use your own resistance values.
- 1 set of safety leads for carrying out the different practical works.
- 1 frame with wheels (H x W x D): 1610 x 940 x 500mm equipped with rack for cords (30 fingers)
- 1 single-phase power console:
 - 1 thermal magnetic circuit breaker (16A)
 - 1 Emergency stop push button with key
 - 1 Push button + LED indicator
 - 1 230V single-phase output on 4mm safety terminals
 - 2 230Vac sockets (2P + E) + 12 230Vac sockets (2P + E), at the back
- Mains power supply 230V - 50/60Hz. 3-metre lead with plug 2P+E.

STUDY OF CONTACTOR + TIMING

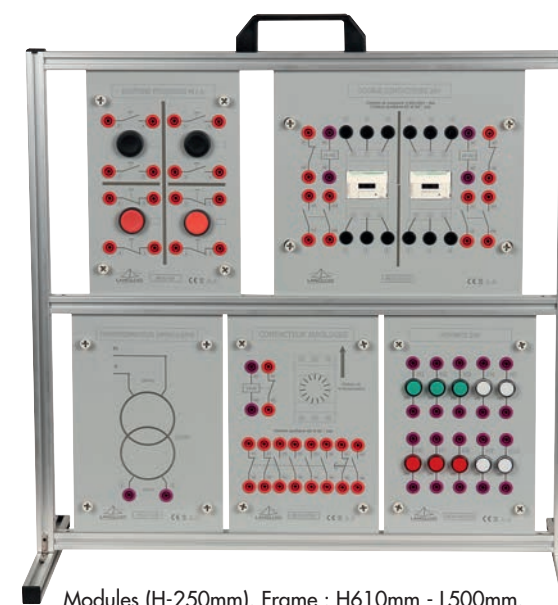

Modules (H-250mm). Frame : H610mm - L500mm.

Powered by 230VAC sector 1,5m cord.

EDUCATIONAL OBJECTIVES

- To study the connection diagram of 2 contactors and 1 timer
- To study the configuration of a timer.

Proposed Practical Works

- Creation of several wiring diagrams of type:
 - on/off
 - on/off with self-maintain
 - on/off with timing.

ref. QUICK-AK10 with frame

ref. QUICK-AK10-N without frame

TEACHING RESSOURCES STUDENT / TEACHER

Comprises

- 1 module 2 auxiliary contactors 24VAC. Contacts 2 x 5 NO + 2 x 1 NC
- 1 module 1 timed contactor with 1 NO + NC timed and 3 NO + 3 NC
- 1 transformer module 230VAC - 24VAC
- 1 module 2 On pushbuttons and 2 Off pushbuttons.
- 1 module of 10 Indicator lights 24VAC.
- 1 set of safety leads for carrying out the different practical works.

STUDY OF THE FEEDING OF PHOTOVOLTAIC ENERGY NATIONAL NETWORK



Set of photovoltaic modules (H-250mm) and solar panels for studying a solar installation with energy feeding to the 230V AC grid.

EDUCATIONAL OBJECTIVES

- Learn about a photovoltaic installation with energy feeding to the grid.
- Study the types of energy feeding to the grid, e.g. total or partial.
- Learn about and understand the photovoltaic elements present.
- Create the wiring of a photovoltaic installation.
- Take the electrical measurements of the different values.
- Study the efficiency and incidences related to the positioning of the solar panels.
- Study the use of a grid inverter and energy meter.

ref. QUICK-MPLUS

ref. QUICK-M

without frame and console

TEACHING RESSOURCES STUDENT / TEACHER

The set can be supplied without the two solar panels, please ask for details.

Proposed Practical Works

- Creation of the complete wiring diagram for feeding all the energy produced by the panels.
- Creation of the complete wiring diagram for feeding the non-consumed energy produced by the panels.
- Take the measurements of voltage, current and power of the solar panels.
- Take the measurements of the fed voltage, current and power.
- Calculation of the efficiency of the installation.

Comprises

- 1 Coupler module of photovoltaic terminals to 4mm terminals.
- 1 Surge arrester module.
- 1 Circuit switching module.
- 1 Double fuse holder module 10x38 gPV.
- 3 Single-phase energy meters modules 63A. Reset key. Resolution 0.1kW
- 1 Grid inverter module 500W. Automatic synchronization with the grid 230V. Input voltage from 65 to 125V DC. Thermal protection integral to the box.
- 1 Module of photovoltaic two-pole circuit-breaker with fault current VDE0126.
- 1 Grid synchronization switch module.
- 1 Module with outlet 2P+E, 4mm terminals.
- 1 Analogue voltmeter/ammeter module.
- 1 Digital voltmeter module.
- 1 Digital ammeter module.
- 2 Solar panels 200Wc on frame that tilts from 5° to 70°.
- 1 Photovoltaic cable, 30 metres.
- 1 set of safety leads for carrying out the different practical works.
- 1 frame with wheels (H x W x D): 1610 x 940 x 500mm equipped with rack for cords (30 fingers)
- 1 single-phase power console:
 - 1 thermal magnetic circuit breaker (16A)
 - 1 Emergency stop push button with key
 - 1 Push button + LED indicator
 - 1 230V single-phase output on 4mm safety terminals
 - 2 230Vac sockets (2P + E) + 12 230Vac sockets (2P + E), at the back
- Mains power supply 230V - 50/60Hz. 3-metre lead with plug 2P+E.



Sockets on the back of the console for connecting the modules



STUDY OF PHOTOVOLTAIC ENERGY ON AN ISOLATED SITE

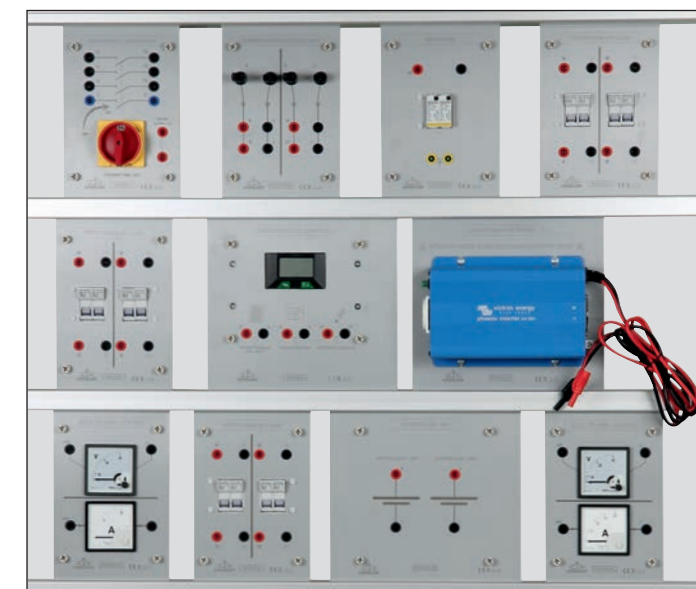

Set of photovoltaic modules (H-250mm) and solar panels for studying a solar installation on an isolated site.

EDUCATIONAL OBJECTIVES

- Apprehend a photovoltaic installation of isolated site type.
- Apprehend and understand the photovoltaic elements involved.
- Perform wiring of a photovoltaic system.
- Perform the electrical measurements of the different values.
- Study the efficiency and incidences of solar panels positioning.
- Study the energy system (production, storage, charge, discharge).
- Study the use of a solar charge controller for batteries.

ref. QUICK-NPLUS

ref. QUICK-N

without frame and console

TEACHING RESSOURCES STUDENT / TEACHER

The set can be supplied without the two solar panels, please ask for details.

Proposed Practical Works

- Creation of the complete wiring diagram.
- Perform parameter setting of the battery charge controller.
- Perform the measurements of voltage, current and power of the solar panels.
- Perform the measurements of voltage, current and power at output 24V DC.
- Calculation of the efficiency of the installation.
- Calculation of the charge/discharge time of the battery.

Comprises

- 1 Coupler module of photovoltaic terminals to 4mm terminals.
- 1 Surge arrester module.
- 1 Circuit switching module.
- 3 Double fuse holder modules 10x38 gPV.
- 1 Solar charge regulator module 24V DC - 20A
- 1 Voltage converter module 350VA - 24V DC - 230V AC on outlet 2P+E.
- 2 Voltmeter/ammeter analogue display modules.
- 1 Two batteries module 12V - 12Ah.
- 2 Solar panels 200Wc on frame that tilts from 5° to 70°.
- 1 Photovoltaic cable of 30 metres.
- 1 set of safety leads for carrying out the different practical works.
- 1 frame with wheels (H x W x D): 1610 x 940 x 500mm equipped with rack for safety leads (30 fingers)
- 1 single-phase power console:
 - 1 thermal magnetic circuit breaker (16A)
 - 1 Emergency stop push button with key
 - 1 ON push button + LED indicator
 - 1 230V single-phase output on 4mm safety terminals
 - 2 230Vac sockets (2P + E) + 12 230Vac sockets (2P + E), at the back
- Mains power supply 230V - 50/60Hz. 3-metre lead with plug 2P+E.



Sockets on the back of the console for connecting the modules





www.langlois-france.com

info@langlois-france.com - Tél. : 0033 556 75 13 33

Z.I. du haut-vigneau 33174 Gradignan cedex